

# United States Court of Appeals for the Federal Circuit

---

**TINNUS ENTERPRISES, LLC, ZURU LTD.,**  
*Plaintiffs-Appellees*

v.

**TELEBRANDS CORPORATION, BED BATH &  
BEYOND, INC.,**  
*Defendants-Appellants*

---

2016-1410

---

Appeal from the United States District Court for the  
Eastern District of Texas in No. 6:15-cv-00551-RWS-JDL,  
Judge Robert Schroeder, III.

---

Decided: January 24, 2017

---

THOMAS MANSFIELD DUNLAP, Dunlap Bennett &  
Ludwig PLLC, Leesburg, VA, argued for plaintiffs-  
appellees. Also represented by DAVID LUDWIG, ERIC  
LORENZ OLAVSON, ROBERT D. SPENDLOVE; CORTLAND  
CHRISTOPHER PUTBRESE, Richmond, VA.

DAVID MICHAEL UNDERHILL, Boies, Schiller & Flexner,  
LLP, Washington, DC, argued for defendant-appellant  
Telebrands Corporation. Also represented by STACEY K.  
GRIGSBY, AMY LYNN NEUHARDT; DAVID BOIES, Armonk,  
NY; ELANA ARAJ, Cooper & Dunham, LLP, New York, NY.

ROBERT THOMAS MALDONADO, ELANA ARAJ, Cooper & Dunham, LLP, New York, NY, appeared for defendant-appellant Bed Bath & Beyond, Inc.

---

Before MOORE, WALLACH, and STOLL, *Circuit Judges*.

STOLL, *Circuit Judge*.

This is an appeal from the grant of a preliminary injunction. The United States District Court for the Eastern District of Texas ruled for the patentee, Tinnus Enterprises, LLC, and entered a preliminary injunction barring Telebrands Corporation from selling its accused product, Balloon Bonanza, or any colorable imitation thereof. Telebrands alleges that the district court abused its discretion by concluding that (1) the asserted claims were likely infringed; (2) the claims were not vulnerable on indefiniteness or obviousness grounds; and (3) Tinnus made a showing of irreparable harm. For the reasons stated below, we disagree with Telebrands and affirm the district court's grant of a preliminary injunction.

#### BACKGROUND

Tinnus Enterprises, LLC produces a toy for filling water balloons covered by U.S. Patent No. 9,051,066, which it calls "Bunch O Balloons." Telebrands Corporation sells a competing product, "Balloon Bonanza." Both products attach to a hose and fill multiple water balloons at once by channeling the water into the balloons through a set of hollow tubes. A side-by-side comparison of the rival products is shown below:

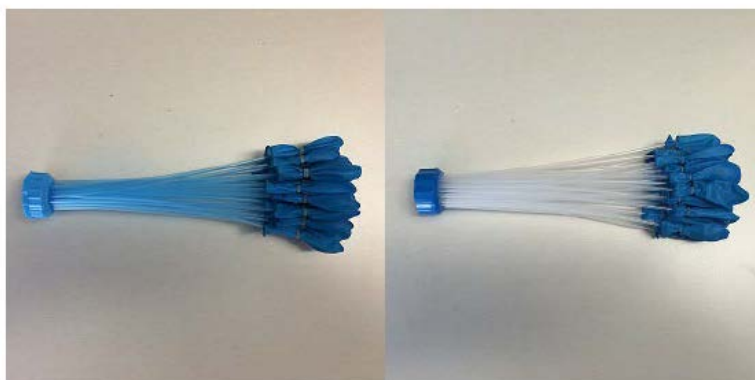
Bunch O BalloonsBalloon Bonanza

Appellee Br. 11.

Tinnus and ZURU Ltd.<sup>1</sup> (collectively, “Tinnus”) sued Telebrands and Bed Bath & Beyond, Inc. (collectively, “Telebrands”) for infringement of the ’066 patent and subsequently moved for a preliminary injunction. The Magistrate Judge issued a Report and Recommendation (“R&R”) in which he recommended granting Tinnus’s motion. *Tinnus Enters., LLC v. Telebrands Corp.*, No. 15-00551, 2015 WL 11089479 (E.D. Tex. Sept. 11, 2015) (*Magistrate Op.*). The district court overruled Telebrands’ objections to the R&R, adopted the R&R’s findings, and granted Tinnus’s motion. *Tinnus Enters., LLC v. Telebrands Corp.*, No. 15-00551, 2015 WL 11089480 (E.D. Tex. Dec. 2, 2015). Shortly thereafter, the Patent Trial and Appeal Board instituted a Post-Grant Review proceeding for the ’066 patent, finding all claims were more likely than not invalid based on the same arguments considered by the district court.

### I. The ’066 Patent

The ’066 patent relates to a system and method for simultaneously filling multiple containers with fluid. ’066

---

<sup>1</sup> ZURU is the exclusive licensee of all present and future patent rights owned by Tinnus that relate to the Bunch O Balloons product.

patent col. 1 ll. 19–21. One application of the '066 patent is the mass-filling of water balloons, as shown in the embodiment depicted in Figure 1:

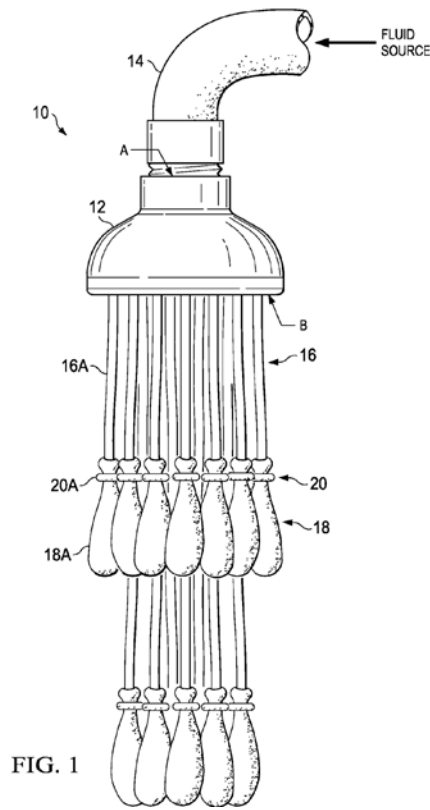

FIG. 1

This embodiment includes a housing 12 with two ends: end A is removably attached to a fluid source, e.g., hose 14, and end B is attached to a plurality of hollow tubes 16. *Id.* col. 2 ll. 35–37. A plurality of containers 18—in this instance, balloons—are clamped to the tubes 16 using elastic valves 20, which can include elastic fasteners, such as O-rings. *Id.* col. 2 ll. 51–59. The patent refers to the force applied by the elastic valves to keep the containers attached to the tubes as the “connecting force.” *Id.* col. 3 ll. 52–64. Once the fluid source is turned on, multiple

balloons are filled simultaneously: fluid flows from hose 14, through the housing 12, and into the containers 18 through the tubes 16. *Id.* col. 3 ll. 41–42.

The '066 patent teaches three ways to overcome the connecting force such that the containers detach from the tubes. These include: (1) pulling the containers away from the tubes, *id.* col. 3 ll. 48–51; (2) shaking the device to overcome the connecting force holding the containers to the tubes, *id.* col. 3 ll. 52–57; and (3) allowing the containers to fall off due to gravity, *id.* col. 3 ll. 65–67. After being detached from the tubes using any of the above-described methods, the elastic valve constricts and seals the balloon. *Id.* col. 4 ll. 64–67.

Independent claim 1 is illustrative, and it recites:

1. An apparatus comprising:

a housing comprising an opening at a first end, and a plurality of holes extending through a common face of the housing at a second end;

a plurality of flexible hollow tubes, each hollow tube *attached* to the housing at a respective one of the holes at the second end of the housing;

a plurality of containers, each container removably attached to a respective one of the hollow tubes; and

a plurality of elastic fasteners, each elastic fastener clamping a respective one of the plurality of containers to a corresponding hollow tube, and *each elastic fastener configured to provide a connecting force that is not less than a weight of one of the containers when substantially filled with water, and to automatically seal its respective one of the plurality of containers upon detaching the container from its corresponding hollow tube, such*

*that shaking the hollow tubes in a state in which the containers are substantially filled with water overcomes the connecting force and causes the containers to detach from the hollow tubes thereby causing the elastic fasteners to automatically seal the containers,*

wherein the apparatus is configured to fill the containers substantially simultaneously with a fluid.

*Id.* col. 6 ll. 30–53 (emphasis added to indicate disputed limitations).

## II. District Court Proceedings

Tinnus filed its patent infringement suit against Telebrands on the day the '066 patent issued and filed a motion for a preliminary injunction nine days later. The Magistrate Judge reviewed the briefing and held a hearing to evaluate evidence on the preliminary injunction factors before recommending that Tinnus's motion be granted.

In his infringement analysis, the Magistrate Judge reviewed Tinnus's claim chart, which mapped the claim limitations onto the Balloon Bonanza product. The claim chart explained why each limitation was met and included photographs of the allegedly infringing product, images from the product instruction manual, screenshots of the product, and related product videos. Telebrands countered that its product did not infringe because its tubes can slide in and out of the housing and therefore are not "attached" to the housing, as required by the claims. Relying on the plain and ordinary meaning of "attached"—"connected or joined to something"—the Magistrate Judge concluded that the "tubes of the Balloon Bonanza product are connected to the housing holes in order for the product to function properly." *Magistrate Op.*, 2015 WL 11089479, at \*4. Telebrands also asserted

that disputes over the meaning of “not less than” in conjunction with the term “connecting force” meant that the elastic fastener limitation was not met.<sup>2</sup> The Magistrate Judge, however, found that this argument was actually premised on Telebrands’ contention that shaking is not required to detach the balloons from the tubes in the Balloon Bonanza product. Because the Balloon Bonanza manual instructs the user to “[t]urn off water and give balloons a shake to release,” *id.* (alteration in original) (quoting J.A. 447), the Magistrate Judge concluded that Balloon Bonanza likely met the disputed limitation, regardless of how it construed “connecting force” or “not less than.”

The Magistrate Judge also found that Telebrands’ indefiniteness and enablement arguments failed to raise a substantial question of validity. First, Telebrands contended that the term “substantially filled” was indefinite because it required subjectivity in determining when the container had become substantially filled. The Magistrate Judge disagreed, noting that there is no per se rule that the term “substantially” is indefinite. The Magistrate Judge further identified “specific parameters” in the claims describing how to determine whether a container is substantially filled—for example, “when the ‘water overcomes the connecting force and causes the containers to detach from the hollow tubes.’” *Id.* at \*5 (quoting ’066 patent col. 6 ll. 48–52). Second, Telebrands alleged that the term “connecting force” was not enabled because the ’066 patent never describes the type of force where the connecting force is not less than the weight of the con-

---

<sup>2</sup> This limitation requires “each elastic fastener configured to provide a connecting force that is not less than a weight of one of the containers when substantially filled with water.” *Magistrate Op.*, 2015 WL 11089479, at \*4 (quoting ’066 patent col. 6 ll. 41–44).

tainer, i.e., when the container will not detach from the tube. The Magistrate Judge disagreed because claim 1 itself recites a shaking limitation for detaching the containers when the connecting force is not less than the weight of the containers when substantially filled with water, which was consistent with the teachings in the specification.

Next, Telebrands argued that claim 1 was obvious over U.S. Patent No. 5,826,803 (“Cooper”) in view of U.S. Patent Publication No. 2013/0118640 (“Saggio”), as well as Cooper in view of Saggio and U.S. Patent Publication No. 2005/0004430 (“Lee”).<sup>3</sup> Cooper discloses a garden sprinkler, as shown in Figure 4 below, that attaches to a garden hose and has multiple bendable tubes 18. ’803 patent col. 2 ll. 22–28, col. 3 ll. 19–23.

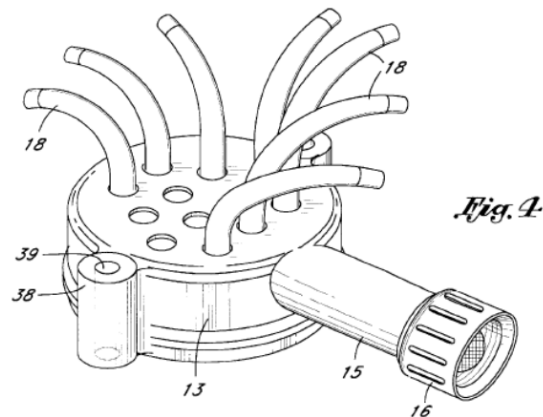

Saggio teaches a system, shown in Figure 7 below, that fills multiple tie-less water balloons simultaneously using a one-way valve, as depicted in Figure 5 reproduced

---

<sup>3</sup> Telebrands offered additional obviousness combinations based on other references at the district court level, but it does not raise them on appeal.



below. When water flows into the balloon through channel 20, the water pressure pushes seal 16 and inner membrane 18 up against the outer wall of the balloon 12, thereby locking in the water and preventing it from escaping. J.A. 741.

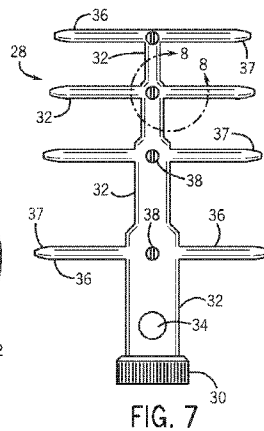
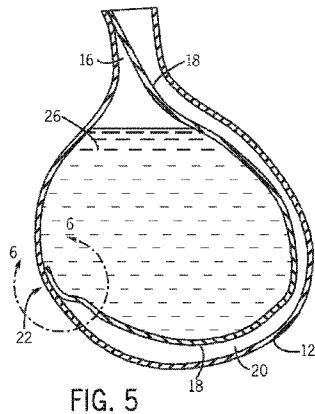

Lee discloses a method and apparatus for endoscopically inserting a balloon into a person's stomach to treat obesity. J.A. 753. As shown in Figure 6, a balloon is attached to the inner guide pipe 3 using a rubber band 2 with a high elastic force that stably binds the balloon to the inner guide pipe when it is expanded. J.A. 754. The outer guide pipe 4 can slide forward towards the balloon once the endoscope and balloon are properly placed inside the stomach, which pushes the rubber band off of inner guide pipe 3 and seals the balloon. *Id.*

FIG. 6

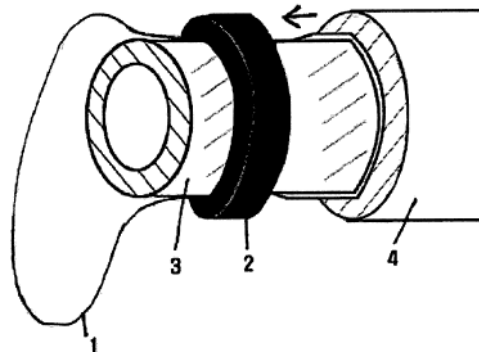

The Magistrate Judge found the combination of Cooper and Saggio deficient because neither reference disclosed the required “elastic fasteners.” The combination of Cooper and Saggio with Lee fared no better because the Magistrate Judge found no evidence that Lee’s rubber band would provide the claimed connecting force. Moreover, the Magistrate Judge was not convinced that a person of ordinary skill in the art (“POSA”) would have been motivated to combine Lee with Cooper and Saggio because the references come from diverse fields: endoscopic balloon insertion devices for obesity treatment, garden sprinklers, and water balloon filling systems, respectively. Finally, even if Telebrands were able to establish a prima facie case of obviousness, the Magistrate Judge noted that secondary considerations, such as commercial success and copying, would be relevant because the Balloon Bonanza product appeared to be “a near identical replica” of the patented Bunch O Balloons product. *Magistrate Op.*, 2015 WL 11089479, at \*7.

With respect to irreparable harm, the Magistrate Judge found evidence of price erosion, consumer confusion, reputational harm, and loss of goodwill based on customer calls, emails, and online reviews. As evidence of price erosion, the Magistrate Judge explained that, while ZURU initially sold Bunch O Balloons for \$17 in August 2014, in response to direct competition from Balloon Bonanza, ZURU reduced the price of Bunch O Balloons to \$12.99, and eventually to \$9.99 by mid-2015. According to the Magistrate Judge, the “market entry and continually reduced sale prices of Telebrands’ allegedly infringing product has driven down the price at which the Bunch O Balloons product has sold,” leading to the “harm that is ultimately irreparable here” in the form of the “now lowered price of sale for the present monopoly right.” *Id.* at \*8 (citing *Douglas Dynamics, LLC v. Buyers Prods. Co.*, 717 F.3d 1336, 1345 (Fed. Cir. 2013) (“Where two companies are in competition against one another, the patentee

suffers the harm—often irreparable—of being forced to compete against products that incorporate and infringe its own patented inventions.”)).

To establish consumer confusion, reputational harm, and loss of good will, Tinnus provided evidence of conversations and reviews from confused customers. For example, the Magistrate Judge cited evidence that one customer called ZURU to inquire about her product order when, in fact, the customer had purchased Balloon Bonanza instead and that another customer left a review online stating “the inventor of the Balloon Bonanza who invented this product was formerly called Bunch O Balloons.” *Id.* Customers also sent emails to Tinnus asking whether Balloon Bonanza was invented by Mr. Malone, Tinnus’s founder, and wondering whether he had licensed his invention to Telebrands. This evidence convinced the Magistrate Judge that consumers were confused about which product is sold by which company and that the patented Bunch O Balloons product had “been diluted in the minds of the consuming public.” *Id.* Aside from the consumer confusion, the false association between the products harmed Tinnus because Bunch O Balloons received better ratings than Balloon Bonanza on Amazon.com and ToysRUs.com. Even though most of these examples pre-dated the issuance of the ’066 patent, the Magistrate Judge found that several of the harms, including customer confusion, were ongoing.

The Magistrate Judge also concluded that the balance of hardships and public interest factors weighed in Tinnus’s favor due to the relative size of the parties and the strong public interest in enforcing valid patents. Because Tinnus established all four factors required for a preliminary injunction, the Magistrate Judge recommended granting Tinnus’s motion.

Telebrands timely filed its objections to the Magistrate Judge’s R&R, alleging that it erred (1) by failing to

provide a claim construction for the “attached,” “connecting force,” “elastic fastener,” and “shaking” limitations; (2) by improperly shifting the burden of proof to Telebrands on infringement and invalidity; and (3) by relying on insufficient evidence to support findings of commercial success and copying.<sup>4</sup> Notably, Telebrands did not object to the Magistrate Judge’s indefiniteness ruling or its rejection of Telebrands’ obviousness arguments. The district court overruled each of the objections, adopted the R&R’s findings, and entered a preliminary injunction.

### III. PTAB Proceedings

Operating in parallel to the district court proceeding was Telebrands’ PGR petition seeking to invalidate the ’066 patent. The PTAB, relying on the same evidence and arguments before the district court, instituted review on all claims of the ’066 patent shortly after the district court granted Tinnus’s request for a preliminary injunction.<sup>5</sup>

The PTAB found that claim 1’s “shake-to-detach” feature<sup>6</sup> was likely indefinite because the specification and

---

<sup>4</sup> Telebrands also objected to the R&R’s findings with respect to irreparable harm, but this portion of its objections was not included in the appellate record. See Defendants’ Objections to the Report and Recommendation Regarding Plaintiffs’ Motion for Preliminary Injunction (Dkt. No. 9) at 4–5, *Tinnus Enters., LLC v. Telebrands Corp.*, No. 15-00551 (E.D. Tex. Sept. 25, 2015), ECF No. 70.

<sup>5</sup> The PTAB instituted review for claims 1–6, 8, and 10–14. Tinnus disclaimed claims 7 and 9. *Telebrands Corp. v. Tinnus Enters., LLC*, PGR2015-18, 2016 WL 270152, at \*1 n.1 (PTAB Jan. 4, 2016) (*Institution Decision*).

<sup>6</sup> The PTAB defined the following italicized claim language as the shake-to-detach feature: “each elastic

prior art both fail to provide “any objective standard for measuring the scope of ‘filled’ or ‘substantially filled,’” and the specification sets forth no limit on the amount of shaking needed to detach a filled container from the tube. *Institution Decision*, 2016 WL 270152, at \*7–8.<sup>7</sup> The PTAB also found that a combination of Cooper, Saggio, and Lee would likely render claim 1 obvious. *Id.* at \*14. According to the PTAB, a POSA would have combined Saggio with Cooper to create a multi-balloon filling assembly by “attach[ing] balloons to the ends of the flexible tubes of Cooper’s sprinkler” and would have added Lee’s mechanism for clamping and sealing the balloons once filled because it was “reasonably pertinent to a particular problem the inventor of the ’066 patent was trying to solve.” *Id.* at \*13.

Telebrands appeals the preliminary injunction entered by the district court. We have jurisdiction pursuant to 28 U.S.C. § 1292(a)(1) and (c)(1).

---

fastener configured to provide a connecting force that is not less than a weight of one of the containers when substantially filled with water, . . . *such that shaking the hollow tubes in a state in which the containers are substantially filled with water overcomes the connecting force and causes the containers to detach from the hollow tubes.*” *Id.* at \*7 (alteration in original).

<sup>7</sup> We are aware that the PTAB issued a Final Written Decision on December 30, 2016, concluding that the claims of the ’066 patent are indefinite. The PTAB’s decision is not binding on this court, and based on the record before us and the applicable standard of review, it does not persuade us that the district court abused its discretion in granting the preliminary injunction. The parties are, of course, free to ask the district court to reconsider its preliminary injunction in light of the PTAB’s Decision.

## DISCUSSION

On appeal, Telebrands challenges the district court’s conclusions on likelihood of success on the merits—including its findings on infringement and invalidity—as well as its conclusions on irreparable harm, which we address in turn.

“A decision to grant or deny a preliminary injunction is within the sound discretion of the district court, based upon its assessment of four factors: (1) the likelihood of the patentee’s success on the merits; (2) irreparable harm if the injunction is not granted; (3) the balance of hardships between the parties; and (4) the public interest.” *Procter & Gamble Co. v. Kraft Foods Glob., Inc.*, 549 F.3d 842, 847 (Fed. Cir. 2008) (quoting *Oakley, Inc. v. Sunglass Hut Int’l*, 316 F.3d 1331, 1338–39 (Fed. Cir. 2003)). With respect to establishing a likelihood of success on the merits, “the patentee seeking a preliminary injunction in a patent infringement suit must show that it will likely prove infringement, and that it will likely withstand challenges, if any, to the validity of the patent.” *Titan Tire Corp. v. Case New Holland, Inc.*, 566 F.3d 1372, 1376 (Fed. Cir. 2009). An accused infringer “can defeat a showing of likelihood of success on the merits by demonstrating a substantial question of validity or infringement.” *Trebro Mfg., Inc. v. Firefly Equip., LLC*, 748 F.3d 1159, 1165 (Fed. Cir. 2014) (citing *Aria Diagnostics, Inc. v. Sequenom, Inc.*, 726 F.3d 1296, 1304 (Fed. Cir. 2013)).

In general, we review preliminary injunctions using the law of the regional circuit—here, the Fifth Circuit—because “[t]he grant, denial, or modification of a preliminary injunction . . . is not unique to patent law.” *Id.* (alteration in original) (quoting *Aevoe Corp. v. AE Tech Co.*, 727 F.3d 1375, 1381 (Fed. Cir. 2013)). “However, the Federal Circuit has itself built a body of precedent applying the general preliminary injunction considerations to a large number of factually variant patent cases, and gives

dominant effect to Federal Circuit precedent insofar as it reflects considerations specific to patent issues.” *Murata Mach. USA v. Daifuku Co.*, 830 F.3d 1357, 1363 (Fed. Cir. 2016) (quoting *Trebro*, 748 F.3d at 1165). Both the Fifth Circuit and the Federal Circuit review preliminary injunctions for an abuse of discretion. *See Sepulvado v. Jindal*, 729 F.3d 413, 417 (5th Cir. 2013); *see also Procter & Gamble*, 549 F.3d at 845. A party can establish an abuse of discretion in the preliminary injunction context “by showing that the court made a clear error of judgment in weighing relevant factors or exercised its discretion based upon an error of law or clearly erroneous factual findings.” *Abbott Labs. v. Andrx Pharm., Inc.*, 452 F.3d 1331, 1335 (Fed. Cir. 2006) (quoting *Polymer Techs., Inc. v. Bridwell*, 103 F.3d 970, 973 (Fed. Cir. 1996)).

Under Fifth Circuit law, where a party fails to object to a magistrate judge’s findings of fact, conclusions of law, or recommendation to the district court, plain error review applies to those unobjected-to factual findings and legal conclusions adopted by the district court. *Douglass v. United Servs. Auto. Ass’n*, 79 F.3d 1415, 1430 (5th Cir. 1996) (en banc), *superseded by statute on other grounds*, 28 U.S.C. § 636(b)(1) (extending time to file objections from ten to fourteen days). “To prevail under [the plain error] standard, the appellant ‘must show (1) that an error occurred; (2) that the error was plain, which means clear or obvious; (3) the plain error must affect substantial rights; and (4) not correcting the error would seriously impact the fairness, integrity, or public reputation of judicial proceedings.’” *Ortiz v. City of San Antonio Fire Dep’t*, 806 F.3d 822, 825–26 (5th Cir. 2015) (quoting *Septimus v. Univ. of Hous.*, 399 F.3d 601, 607 (5th Cir. 2005)). “When the nature of the claimed error is a question of fact, however, the possibility that such a finding could rise to the level of obvious error required to meet part of the standard for plain error is remote.” *Casas v. Aduddell*, 404 F. App’x 879, 881 (5th Cir. 2010).

## I. Patent Infringement

On appeal, Telebrands first faults the district court for failing to construe the terms “not less than” and “connecting force.” Telebrands also alleges clear error in the district court’s conclusions that the Balloon Bonanza tubes are “attached” to the housing and meet the shake to detach limitation. For the reasons explained below, none of these arguments are persuasive.

An infringement analysis involves the two-step process of “construing the claims and comparing the properly construed claims to the accused product.” *Advanced Steel Recovery, LLC v. X-Body Equip., Inc.*, 808 F.3d 1313, 1316 (Fed. Cir. 2015). Infringement is a question of fact, which we review on appeal for clear error. *See AstraZeneca LP v. Apotex, Inc.*, 633 F.3d 1042, 1056 (Fed. Cir. 2010).

Contrary to Telebrands’ argument, the R&R, which was adopted by the district court, did not refuse to construe the terms “not less than” and “connecting force.” Instead, the R&R acknowledged Telebrands’ disagreement regarding those terms but concluded that Tinnus was likely to succeed on its infringement claim “irrespective of the interpretation of these claim terms.” *Magistrate Op.*, 2015 WL 11089479, at \*4. The R&R reached this conclusion because it found that Telebrands’ claim construction argument hinged on the contention that shaking is not required to detach the balloons from the tubes. Because the Balloon Bonanza instruction manual tells users to “[t]urn off water and give balloons a shake to release,” *id.* (alteration in original), the Magistrate Judge determined that Telebrands’ position conflicted with the record evidence and failed to demonstrate that Tinnus was unlikely to succeed on its infringement claim. It was not clear error for the district court to adopt this finding.

Next, Telebrands challenges the district court’s application of the claim term “attached” to the Balloon Bonanza product because its tubes allegedly “do not connect or



join to the housing, but rather slide in and out of the holes in the common face of the housing.” Appellant Br. 24–25. The R&R applied the plain and ordinary meaning for the term “attached,” i.e., “connected or joined to something,” and found that the Balloon Bonanza product’s tubes must be “connected to” the housing’s holes in order for it to function properly. *Magistrate Op.*, 2015 WL 11089479, at \*4 (citing Merriam-Webster Dictionary, <https://www.merriam-webster.com/dictionary/attached> (last visited Dec. 19, 2016)). This must be so, according to the R&R, because the housing accepts water from the hose at one end and sends the water through the holes at the other end, which are connected to hollow tubes for filling the balloons. The R&R’s analysis of the “attached” limitation is reasonable, and the district court’s adoption of it does not constitute clear error.

Finally, Telebrands alleges that each claim limitation must be found in the accused product itself, and that it was clear error for the Magistrate Judge to rely on Balloon Bonanza’s instruction manual to satisfy the shaking limitation. We disagree. The instructions for the Balloon Bonanza product are at least circumstantial evidence of infringement for any claim elements taught by those materials. A patentee is entitled to rely on circumstantial evidence to establish infringement: “If [Defendant] is arguing that proof of inducing infringement or direct infringement requires direct, as opposed to circumstantial evidence, we must disagree. It is hornbook law that direct evidence of a fact is not necessary.” *Moleculon Research Corp. v. CBS, Inc.*, 793 F.2d 1261, 1272 (Fed. Cir. 1986), *abrogated on other grounds by Egyptian Goddess, Inc. v. Swisa, Inc.*, 543 F.3d 665 (Fed. Cir. 2008) (en banc), *as recognized in VirtualAgility Inc. v. Salesforce.com, Inc.*, 759 F.3d 1307, 1318 (Fed. Cir. 2014). Indeed, this court has previously approved of the use of instruction manuals to demonstrate direct infringement by customers in the context of induced infringement. *Golden Blount, Inc. v.*

*Robert H. Peterson Co.*, 438 F.3d 1354, 1362–63 (Fed. Cir. 2006) (“We reject [Defendant]’s argument that [the patentee] could not rely on the instruction sheets to prove acts of direct infringement by end-users.”); *see also Moleculon*, 793 F.2d at 1272 (affirming district court’s finding of induced infringement based, in part, on instruction sheet).

The cases Telebrands cites to the contrary are not persuasive. *MicroStrategy* stands for the unremarkable proposition that every claim limitation must be met to establish literal infringement and says nothing about product instructions. *MicroStrategy Inc. v. Bus. Objects, S.A.*, 429 F.3d 1344, 1352–53 (Fed. Cir. 2005). The pertinent portion of the *Vita-Mix* case relates to an induced infringement analysis where the Plaintiff attempted to use the accused infringer’s instructions to establish an intent to induce infringement. *Vita-Mix Corp. v. Basic Holding, Inc.*, 581 F.3d 1317, 1328 (Fed. Cir. 2009). There, we disregarded the instructions because they did not support the inference of intent to infringe, not because reliance on the instructions would be legally improper. *Id.* at 1328–29. We are aware of no case law prohibiting a court from relying on product instructions to find direct infringement. Accordingly, the district court did not clearly err in relying on Telebrands’ instruction manual as part of its infringement analysis.

## II. Patent Validity

“The burden on the accused infringer to show a substantial question of invalidity at [the preliminary injunction] stage is lower than what is required to prove invalidity at trial.” *Altana Pharma AG v. Teva Pharm. USA, Inc.*, 566 F.3d 999, 1006 (Fed. Cir. 2009). “Vulnerability is the issue at the preliminary injunction stage, while validity is the issue at trial.” *Amazon.com, Inc. v. Barnesandnoble.com, Inc.*, 239 F.3d 1343, 1359 (Fed. Cir. 2001). Telebrands contends that the Magistrate Judge

improperly shifted the burden of proving invalidity to Telebrands, rather than requiring Tinnus to establish a likelihood of success in proving the patent’s validity. This argument is not compelling.

Each issued patent carries with it a presumption of validity under 35 U.S.C. § 282. *Titan Tire*, 566 F.3d at 1376–77. This presumption is sufficient to establish a likelihood of success on the validity issue, absent a challenge by the accused infringer. *Id.* at 1377. Where the alleged infringer attacks the validity of the patent, “the burden is on the challenger to come forward with evidence of invalidity,” which the patentee must then rebut. *Id.* at 1377–78. “[I]f the trial court concludes there is a ‘substantial question’ concerning the validity of the patent, meaning that the alleged infringer has presented an invalidity defense that the patentee has not shown lacks substantial merit, it necessarily follows that the patentee has not succeeded in showing it is likely to succeed at trial on the merits of the validity issue.” *Id.* at 1379. The district court properly applied this analytical framework.

#### A. Indefiniteness

Telebrands contends that the claim term “substantially filled” is indefinite because a POSA would not be able to determine whether an expandable container meets this limitation.<sup>8</sup>

“[A] patent is invalid for indefiniteness if its claims, read in light of the specification delineating the patent, and the prosecution history, fail to inform, with reasona-

---

<sup>8</sup> Telebrands also argues that “connecting force” is indefinite, but its argument turns on the indefiniteness of “substantially filled.” See Appellant Br. 14 (“Without knowing what volume of water constitutes ‘substantially filled,’ one skilled in the art cannot know its weight, thus rendering the ‘connecting force’ indefinite.”).

ble certainty, those skilled in the art about the scope of the invention.” *Nautilus, Inc. v. Biosig Instruments, Inc.*, 134 S. Ct. 2120, 2124 (2014). Because Telebrands did not object to the R&R’s indefiniteness determination, we review the district court’s determination on indefiniteness for plain error. *Douglass*, 79 F.3d at 1430.

Telebrands attempts to circumvent this deferential standard of review by arguing that objecting to the R&R’s claim construction, or lack thereof, put the Magistrate Judge on notice that it was contesting the definiteness of “substantially filled.” We disagree. Nowhere in its objections to the R&R does Telebrands mention the word “indefinite,” J.A. 1986–88, and “substantially filled” is not even among the terms flagged by Telebrands—“attached,” “connecting force,” “elastic fastener,” and the “shaking” limitation—as requiring construction. *Id.* We fail to see how seeking the construction of different, albeit related, claim terms would put the district court on notice of Telebrands’ objection to the R&R’s conclusion that “substantially filled” was not indefinite.

Turning to the merits, Telebrands argues on appeal that the ’066 patent creates a subjective standard for determining whether a container is “substantially filled” because the specification makes frequent references to detaching the containers when they reach a “desired size.” Appellant Br. 13–14. The specification, however, does not define or equate “substantially filled” with “desired size.” And the claims themselves teach that shaking causes the containers to detach from the hollow tubes when they are “substantially filled” with water, ’066 patent col. 6 ll. 46–51, meaning that shaking will not detach the containers if they are not “substantially filled.” To put a finer point on it, if the balloons detach after shaking, then they are “substantially filled.” The R&R cited a portion of this claim language to support its conclusion that the ’066 patent provided “specific parameters” for determining

when the containers are “substantially filled.” *Magistrate Op.*, 2015 WL 11089479, at \*5.

Telebrands alleges that the R&R’s reliance on a portion of this claim language for determining when a container is “substantially filled” was based on a truncated and incorrect reading of the claim. The R&R says, “containers are substantially filled with water when the ‘water overcomes the connecting force and causes the containers to detach from the hollow tubes.’” *Id.* (quoting ’066 patent col. 6 ll. 48–52). According to Telebrands, shaking, not the water, overcomes the connecting force. Although shaking does contribute to the detachment, as discussed above, the claims specifically call for detachment by shaking when the container is “substantially filled” with water. Thus, we do not find this argument persuasive.

In addition to the reasons set forth in the R&R, the level of ordinary skill in the art plays an important role in an indefiniteness analysis. Telebrands asserts that a POSA has “a general knowledge about and experience with expandable containers, including without limitation balloons, and at least an associate’s degree in science or engineering.” J.A. 835–36 ¶¶ 10–13. We find it difficult to believe that a person with an associate’s degree in a science or engineering discipline who had read the specification and relevant prosecution history would be unable to determine with reasonable certainty when a water balloon is “substantially filled.”

For these reasons, the district court’s conclusion that Telebrands’ indefiniteness argument failed to raise a substantial question of validity does not suffer from a “clear or obvious” error, *Ortiz*, 806 F.3d at 825–26, requiring reversal under plain error review. Because we find no clear or obvious error, we need not address the other plain error factors articulated by the Fifth Circuit in *Ortiz*.

## B. Obviousness

On appeal, Telebrands advances several arguments relating to the combination of the Cooper, Saggio, and Lee references. Because Telebrands did not object to the factual findings and legal conclusions in the R&R relating to obviousness, we review the district court’s obviousness analysis for plain error.<sup>9</sup>

A claim is unpatentable as obvious “if the differences between the claimed invention and the prior art are such that the claimed invention as a whole would have been obvious before the effective filing date of the claimed invention to a person having ordinary skill in the art.” 35 U.S.C. § 103. The law is clear, however, that “a patent composed of several elements is not proved obvious merely by demonstrating that each of its elements was, independently, known in the prior art.” *KSR Int’l Co. v. Teleflex Inc.*, 550 U.S. 398, 418 (2007). Indeed, “it can be important to identify a reason that would have prompted a person of ordinary skill in the relevant field to combine the elements in the way the claimed new invention does.” *Id.*

Telebrands argues that the district court erred because it found there was no motivation to combine the prior art references without first considering whether Lee was reasonably pertinent to the particular problem the inventor solved. More specifically, Telebrands alleges that Cooper, Saggio, and Lee each relate to the same problem addressed by the ’066 patent: “automatically sealing a balloon or multiple balloons at one time.” Appellant Br. 17–18. A prior art reference is analogous and

---

<sup>9</sup> Telebrands conceded that plain error review applies during oral argument. See Oral Arg. at 6:10–6:30, <http://oralarguments.cafc.uscourts.gov/default.aspx?fl=2016-1410.mp3>.

thus can be used in an obviousness combination if it “is from the same field of endeavor, regardless of the problem addressed” or “is reasonably pertinent to the particular problem with which the inventor is involved,” even if it is not within the inventor’s field of endeavor. *Unwired Planet, LLC v. Google Inc.*, 841 F.3d 995, 1000–01 (Fed. Cir. 2016) (quoting *In re Clay*, 966 F.2d 656, 658–59 (Fed. Cir. 1992)). The particular problem confronting the inventor here was how to rapidly fill multiple containers with fluid. This is far removed from the problems associated with an endoscopic balloon insertion device for treating obesity, and Telebrands has not demonstrated that Lee is reasonably pertinent to the problem addressed in the ’066 patent. Therefore, under a plain error review, we cannot say that the district court committed a clear or obvious error when it found insufficient motivation to combine these disparate references. Absent a motivation to combine, Telebrands’ remaining obviousness arguments are unavailing.

### III. Irreparable Harm

Finally, Telebrands alleges that it was clear error for the Magistrate Judge to rely on evidence pre-dating the ’066 patent’s issuance in support of its finding of irreparable harm. Citing *GAF Building Materials Corp. v. Elk Corp. of Dallas*, 90 F.3d 479 (Fed. Cir. 1996), Telebrands asserts that irreparable harm must be measured from the date the patent issues because that is the date on which the right to exclude others arises. The *GAF* case is inapposite, however, because it addresses the dismissal for lack of jurisdiction of an action for declaratory judgment of invalidity and noninfringement of a design patent that had not yet issued. *Id.* at 481–83. And Telebrands cites no case prohibiting reliance on evidence of irreparable harm pre-dating the patent’s issuance.

Evidence of consumer confusion, harm to reputation, and loss of goodwill pre-dating the patent is, at the very

least, circumstantial evidence demonstrating the possibility of identical harms once the patent issues. Neither party has suggested that the issuance of a patent would somehow mitigate or otherwise eliminate those harms. Similarly, the pre-issuance price erosion evidence may be relevant to show what would happen if Balloon Bonanza was no longer on the market. For example, it might support an argument that, absent competition, Tinnus could raise its price back to the original price point, but would not be able to do so as long as competition from Balloon Bonanza remains.

Nonetheless, the irreparable harm analysis does not depend solely on evidence pre-dating the patent. The record contains additional evidence of harm after the '066 patent's issuance that is sufficient to support a finding of irreparable harm. For example, a review for Tinnus's Bunch O Balloons product on Amazon—dated a few weeks after the patent issued—states that the customer liked the “off brand” Bunch O Balloons product better than the “name brand” Balloon Bonanza. J.A. 1436. This establishes persisting harm to Tinnus's reputation and tarnishes its status as the innovator in this market. *See Celsis In Vitro, Inc. v. CellzDirect, Inc.*, 664 F.3d 922, 930 (Fed. Cir. 2012) (“Price erosion, loss of goodwill, damage to reputation, and loss of business opportunities are all valid grounds for finding irreparable harm.”). Although the post-issuance evidence is thinner, we are unable to find any clear error in the district court's conclusion that Tinnus had demonstrated irreparable harm.

#### CONCLUSION

For the reasons stated above, the district court did not abuse its discretion in granting the preliminary injunction. Accordingly, we affirm the district court's judgment.

**AFFIRMED**



COSTS

Costs to Appellees.