

UNITED STATES PATENT AND TRADEMARK OFFICE

BEFORE THE PATENT TRIAL AND APPEAL BOARD

TELEBRANDS CORP.,
Petitioner,

v.

TINNUS ENTERPRISES, LLC,
Patent Owner.

Case PGR2015-00018
Patent 9,051,066 B1

Before PHILLIP J. KAUFFMAN, RICHARD E. RICE, and
TIMOTHY J. GOODSON, *Administrative Patent Judges*.

RICE, *Administrative Patent Judge*.

FINAL WRITTEN DECISION
35 U.S.C. § 328(a) and 37 C.F.R. § 42.73

I. INTRODUCTION

A. Summary

Telebrands Corp. (“Petitioner”) filed a Petition (Paper 1, “Pet.”) requesting post-grant review of claims 1–14 of U.S. Patent No. 9,051,066 B1 (Ex. 1001, “the ’066 Patent”). Petitioner supported the Petition with declarations of Dr. Ken Kamrin (Ex. 1015), Dr. Greg Saggio (Ex. 1016), and Kendall Harter (Ex. 1017).

Tinnus Enterprises, LLC (“Patent Owner”) filed a Preliminary Response (Paper 6, “Prelim. Resp.”), as well as a statutory disclaimer disclaiming claims 7 and 9.

We instituted a trial as to claims 1–6, 8, and 10–14, on the following grounds:

Reference(s)	Basis	Claims Challenged
	§ 112(b)	1–6, 8, and 10–14
US 5,826,803 (“Cooper,” Ex. 1009), US 2013/0118640 A1 (“Saggio,” Ex. 1010), and (US 2005/0004430 A1 (“Lee,” Ex. 1011)	§ 103(a)	1–4, 8, and 14
Cooper, Saggio, Lee, and US 8,479,776 B2 (“Berardi,” Ex. 1014)	§ 103(a)	11–13

Paper 7 (“Inst. Dec.”), 5–6, 26–27.

After institution of the trial, Patent Owner filed a corrected Patent Owner Response¹ (Paper 50, “PO Resp.”), to which Petitioner filed a Reply (Paper 53, “Pet. Reply”). Patent Owner supported the Patent Owner

¹ Patent Owner also filed a Patent Owner Response (lacking page numbers) (Paper 40) and a Redacted Patent Owner Response (Paper 39).

Response with declarations of Josh Malone (Ex. 2014), Anna Mowbray (Ex. 2019), Barry Kudrowitz, Ph.D. (Ex. 2020), Jonathan E. Hochman (Ex. 2024), and Dr. Ray Perryman (Ex. 2025).² Petitioner supported the Reply with a declaration from Vishal J. Parikh (Ex. 1026).

Patent Owner filed a Motion to Exclude (Paper 57), to which Petitioner filed an Opposition (Paper 66), and Patent Owner filed a Reply (Paper 67). Petitioner also filed a Motion to Exclude (Paper 59), to which Patent Owner filed an Opposition (Paper 64), and Petitioner filed a Reply (Paper 68).

Patent Owner did not move to amend any claim of the '066 Patent.

We heard oral argument on September 23, 2016. A transcript of the argument has been entered in the record (Paper 73 (confidential portion), Paper 74, "Tr" (public portion)). Below, we cite only to the public portion of the transcript.

We have jurisdiction under 35 U.S.C. § 6(b)(4). The evidentiary standard is a preponderance of the evidence. *See* 35 U.S.C. § 326(e); 37 C.F.R. § 42.1(d). This Final Written Decision is issued pursuant to 35 U.S.C. § 328(a) and 37 C.F.R. § 42.73.

For the reasons explained below, we conclude that Petitioner has demonstrated by a preponderance of evidence that claims 1–6, 8, and 10–14 of the '066 Patent are unpatentable. We deny the parties' respective Motions to Exclude.

² Patent Owner also filed Redacted Declaration of Dr. Ray Perryman (Ex. 2026).

B. Related Matters

The parties identify a federal district court case involving the '066 Patent (*Tinnus Enterprises, LLC v. Telebrands Corp.*, Civil Action No. 6:15-cv-00551-RWS-JDL (E.D. Tex.)). Pet. 3; Prelim. Resp. 7.

C. The '066 Patent

The '066 Patent, titled "System and Method for Filling Containers with Fluids," issued from U.S. Application No. 14/492,487, filed September 22, 2014. Ex. 1001, at (54), (21), (22). Figure 1 of the '066 Patent is reproduced below.

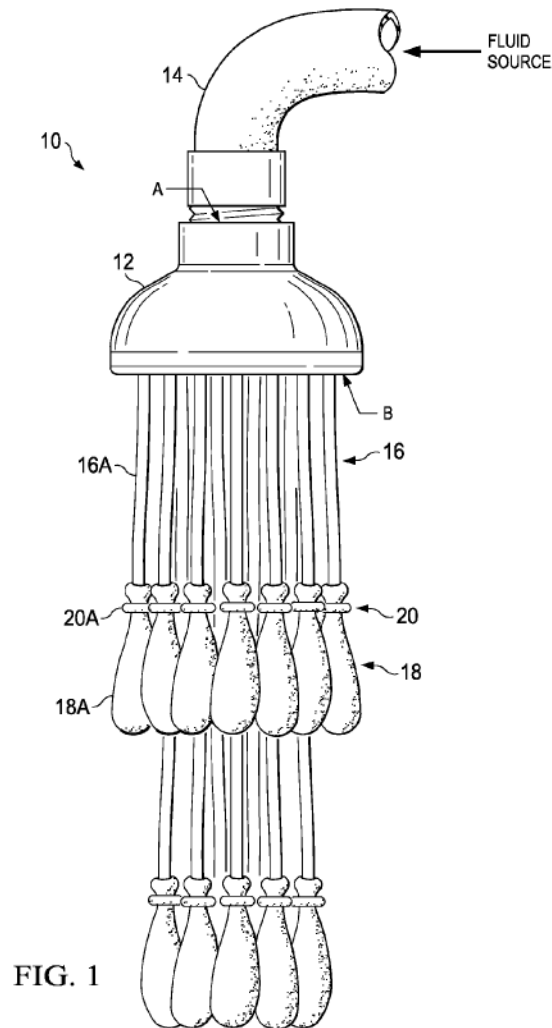

Figure 1 is a simplified diagram illustrating an example embodiment of a system for filling containers with fluids. *Id.* at 2:33–34. As shown in Figure 1, system 10 includes housing 12 removably attached to hose 14 at end A and to a plurality of hollow tubes 16 at end B. *Id.* at 2:35–37. A plurality of containers 18, such as inflatable balloons, may be clamped to plurality of tubes 16 using elastic valves 20, which may comprise elastic fasteners such as O-rings. *Id.* at 2:51–59, 3:19–20. In addition to inflatable balloons, “containers 18 may comprise flexible containers that may be filled with body fluids.” *Id.* at 3:30–32. In some embodiments, containers 18 need not be inflatable or flexible in their entireties. *Id.* at 3:35–36.

Figure 2 of the '066 Patent is reproduced below.

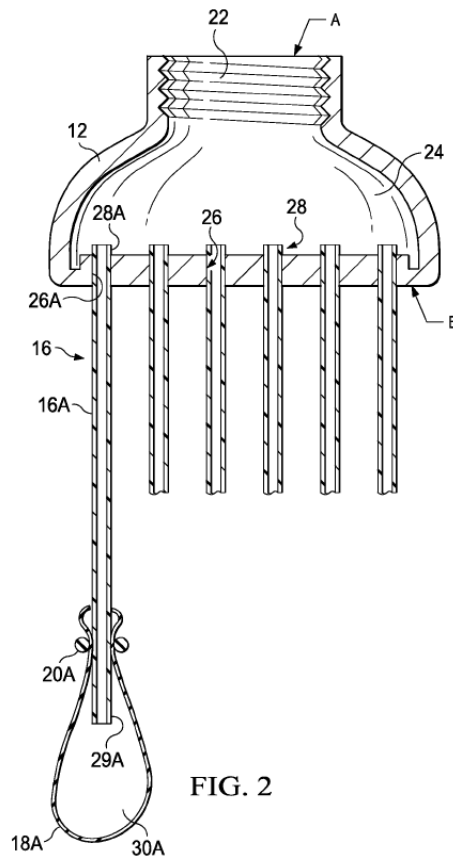

Figure 2 is a simplified cross-sectional view of a portion of an embodiment of system 10. *Id.* at 4:31–32. As shown, an end of tube 16A is inserted into container 18A, and elastic valve 20A clamps the neck of the container to the tube. *Id.* at 4:48–53. “An internal volume 30A of container 18A may be filled with fluid appropriately.” *Id.* at 4:53–54. “When containers 18 have reached a desired size and/or they are filled with the desired volume of fluid, they may be removed from tubes 16. They can be removed . . . by shaking them off.” *Id.* at 4:60–63. As each container 18A is removed, the elastic valve constricts and closes the neck of the container, sealing it with the fluid inside. *Id.* at 4:64–67.

D. Illustrative Claim

Claim 1, which is the sole independent claim, is illustrative of the claimed subject matter, and is reproduced below:

1. An apparatus comprising:
 - a housing comprising an opening at a first end, and a plurality of holes extending through a common face of the housing at a second end;
 - a plurality of flexible hollow tubes, each hollow tube attached to the housing at a respective one of the holes at the second end of the housing;
 - a plurality of containers, each container removably attached to a respective one of the hollow tubes; and
 - a plurality of elastic fasteners, each elastic fastener clamping a respective one of the plurality of containers to a corresponding hollow tube, and each elastic fastener configured to provide a connecting force that is not less than a weight of one of the containers when substantially filled with water, and to automatically seal its respective one of the plurality of containers upon detaching the container from its corresponding hollow tube, such

that shaking the hollow tubes in a state in which the containers are substantially filled with water overcomes the connecting force and causes the containers to detach from the hollow tubes thereby causing the elastic fasteners to automatically seal the containers,

wherein the apparatus is configured to fill the containers substantially simultaneously with a fluid.

Id. at 6:30–53.

II. ANALYSIS

A. *Level of Skill in the Art*

Petitioner contends that a person of ordinary skill in the art (“POSA”) “would have been a person having a general knowledge about and experience with expandable containers, including without limitation balloons, and at least an associate’s degree in science or engineering.”

Pet. 15–16 (citing Ex. 1015 ¶¶ 10–13; Ex. 1016 ¶¶ 10–13). Patent Owner responds that “the Board should limit Petitioner’s overly broad definition of a POSA from having an associate’s degree in any science or engineering to having an associate’s degree in mechanical engineering.” *See, e.g.*, PO Resp. 12. According to Patent Owner, “Petitioner’s proposed definition should be limited because the inclusion of persons with an associate’s degree in any science or engineering fails to take into account the scope of the relevant art, which indisputably utilizes mechanical engineering principles.”

Id. Upon consideration of the parties’ contentions, we determine that a POSA would have been a person having a general knowledge about and experience with expandable containers, including without limitation balloons, and at least an associate’s degree in mechanical engineering, or the equivalent.

B. Claim Construction

In an *inter partes* review, the Board gives claim terms in an unexpired patent their broadest reasonable interpretation in light of the specification of the patent in which they appear. 37 C.F.R. § 42.100(b); *see Cuozzo Speed Techs., LLC v. Lee*, 136 S. Ct. 2131, 2144–46 (2016). Under that standard, a claim term generally is given its ordinary and customary meaning, as would be understood by one of ordinary skill in the art in the context of the entire disclosure. *See In re Translogic Tech., Inc.*, 504 F.3d 1249, 1257 (Fed. Cir. 2007). While our claim interpretation “cannot be divorced from the specification and the record evidence,” *see Microsoft Corp. v. Proxyconn, Inc.*, 789 F.3d 1292, 1298 (Fed. Cir. 2015) (quoting *In re NTP, Inc.*, 654 F.3d 1279, 1288 (Fed. Cir. 2011)), we must be careful not to import limitations from the specification that are not part of the claim language, *see SuperGuide Corp. v. DirecTV Enters., Inc.*, 358 F.3d 870, 875 (Fed. Cir. 2004). Any special definition for a claim term must be set forth in the specification with reasonable clarity, deliberateness, and precision. *See In re Paulsen*, 30 F.3d 1475, 1480 (Fed. Cir. 1994).

1. “elastic fastener”

In our Institution Decision, we preliminarily determined that the broadest reasonable interpretation consistent with the Specification of the claim term “elastic fastener” is an elastic element for attaching things together. Inst. Dec. 7–8. As neither party proposes any change to our interpretation, and our review of the evidence does not indicate that any change is necessary, we maintain that interpretation.

2. “*not less than*”

In our Institution Decision, we preliminarily determined that the broadest reasonable interpretation consistent with the Specification of the claim term “not less than” is equal to or greater than. *Id.* at 8. As neither party proposes any change to our interpretation, and our review of the evidence does not indicate that any change is necessary, we maintain that interpretation.

3. “*container*”

In our Institution Decision, we preliminarily determined that the broadest reasonable interpretation consistent with the Specification of the claim term “container” is an object that can hold something, such as fluids. *Id.* at 8–9. As neither party proposes any change to our interpretation, and our review of the evidence does not indicate that any change is necessary, we maintain that interpretation.

4. “*shaking*”

Patent Owner argues that “a POSA would understand [‘]shaking[’] to mean ‘applying an acceleration.’” PO Resp. 15. Patent Owner quotes the Specification in support of its construction:

In another example embodiment, the connecting force holding filled containers 18 to tubes 16 may be overcome *by an upward acceleration* on tubes 16, *for example, when they are shaken*. Thus, filled containers 18 may be detached by shaking housing 12 (or tubes 16) sufficiently vigorously to cause containers 18 to fall off from tubes 16.

Id. at 15 (citing Ex. 1001, 3:52–57). Petitioner does not oppose Patent Owner’s construction.

We agree with, and adopt, Patent Owner’s proposed construction. We determine that the broadest reasonable interpretation consistent with the Specification of “shaking” is applying an acceleration.

5. “filled” and “substantially filled”

We discuss Patent Owner’s proposed constructions of “filled” and “substantially filled” *infra* in Section II.B.

B. Challenge under 35 U.S.C. § 112(b)

Petitioner challenges claims 1–6, 8, and 10–14 as unpatentable for indefiniteness under 35 U.S.C. § 112(b).³ For the reasons discussed below, we determine that Petitioner has established, by a preponderance of the evidence, that the challenged claims are unpatentable.

1. The § 112(b) Contentions of the Parties

Petitioner contends that the claim term “substantially filled” as set forth in claim 1 is indefinite under 35 U.S.C. § 112(b). Pet. 20–24. Petitioner first focuses its arguments on “filled.” *Id.* at 21–23. Petitioner argues that “an expandable container can be considered ‘filled’ at any time prior to when the expandable container reaches its expansion limit and explodes.” *Id.* at 22 (citing Ex. 1015 ¶ 57). According to Petitioner, the Specification “sets forth that the expandable containers are only ‘filled’ when an individual subjectively determines that a ‘desired size’ of a container has been reached.” *Id.* at 23 (citing Ex. 1001, 3:48–49, 4:60–62).

³ 35 U.S.C. § 112(b) provides: “The specification shall conclude with one or more claims particularly pointing out and distinctly claiming the subject matter which the inventor or a joint inventor regards as the invention.”

Petitioner additionally argues that “[t]he lack of clarity of the term ‘filled’ is further enhanced by the modifier, ‘substantially,’ which is a term of degree.” *Id.* at 24. Petitioner asserts that “[t]he specification and prosecution history do not provide objective boundaries for those of ordinary skill in the art for the term ‘filled,’ let alone the term ‘substantially filled.’” *Id.* Additionally, Petitioner contends that the claim term “connecting force” is indefinite under 35 U.S.C. § 112(b). *Id.* at 24–26. Petitioner argues:

Because the specification of the ’066 Patent does not provide an objective boundary for when an expandable container is “substantially filled,” it follows that a person of ordinary skill in the art at the time of the invention of the ’066 Patent would not be able to determine, with reasonable certainty, the amount of the connecting force that the elastic fastener is configured to provide.

Id. (citing Ex. 1015 ¶¶ 60).

Patent Owner responds that, “[u]nder [35 U.S.C.] § 112(b), all that is required is ‘that a patent’s claims, viewed in light of the specification and prosecution history, inform those skilled in the art about the scope of the invention *with reasonable certainty.*’” PO Resp. 65–66 (citing *Nautilus, Inc. v. Biosig Instruments, Inc.*, 134 S. Ct. 2120, 2124 (2014) (emphasis added)). According to Patent Owner, “Petitioner’s argument that the term ‘substantially filled’ is purely subjective ignores the claim language itself,” and “[w]hether a container is ‘substantially filled’ can be understood with reasonable certainty by a POSA just by reading the claim.” *Id.* at 66–67 (citing Ex. 2020 ¶¶ 26, 47).

Patent Owner argues that the meaning of “filled,” in the context of the claims, “is evident in the very experiential, plain and ordinary meaning of the word.” *Id.* at 69 (citing Ex. 2020 ¶¶ 28, 31). Dr. Kudrowitz provides the

following testimony with respect to the meaning of “filled” and “substantially filled”:

30. A container in its operable state is always filled with something. That something may be a gas, a liquid, or a solid, or a combination thereof.

31. For example, an “empty” coffee mug is filled with atmospheric air (possibly including environmental particulates). A coffee mug containing coffee, *to its brim, is filled* with coffee. An “empty” coffee mug into which are placed as many glass marbles as it can hold, *to its brim, is filled* with marbles and atmospheric air [emphasis added].

32. A POSA would interpret “substantially” in this case to mean “approximately.” That is a POSA would understand “substantially filled with water” to mean “approximately filled with water.” A determination of whether a container is substantially filled with a particular material can be performed when the container's volume is fixed or static.

Ex. 2020 ¶¶ 30–32; *see also* PO Resp. 73–74 (citing Ex. 2020 ¶ 32) (“The term ‘substantially’ should be viewed as a term of approximation, and, a POSA would interpret ‘substantially’ in this case to mean ‘approximately.’”).

Patent Owner additionally argues that “[n]ot only are the objective boundaries for ‘substantially filled’ found in the claim itself, they can be found in the specification and prosecution history.” PO Resp. 67. In that regard, Patent Owner asserts:

A POSA would find that the specification provides sufficient objective boundaries for “substantially filled.” (Ex. 2020, Kudrowitz Decl., ¶ 26; Ex. 1001, at 3:52–55 (“[i]n another example embodiment, the connecting force holding filled containers 18 to tubes 16 may be overcome by an upward acceleration on tubes 16, for example when they are shaken.”).) These boundaries were also understood by the Examiner when

amending the claim to add the shaking limitation. (Ex. 2010, 154–155.) (“the language beginning with ‘such that shaking . . .’ defines an *upper limit* of the connecting force and thus defines the elastic fastener in a way which distinguishes over Urspringer”) (emphasis added.)

Id. at 67–68.

Patent Owner also asserts that “[t]he entire claim limitation defines, through functional language, the strength of the elastic fastener and the resulting cooperation of the claimed components, namely the elastic fasteners, the hollow tubes and the containers.” *Id.* at 76. Patent Owner further asserts that “[t]he only (and important) reason that water is provided in the claim is to define the functional cooperation of selected components.” *Id.* at 77 (citing Ex. 2020 ¶¶ 33–37). Dr. Kudrowitz testifies:

If the functions of the elastic fastener are achievable at a time when the container is in a state of having been substantially filled with water, then the selected elastic fastener would fall within the requirements of the claim. If a POSA would want to avoid infringement of the claim by avoiding the claimed functionality, he or she would merely have to choose a weaker or stronger elastic fastener that would not achieve the functionality specified by the claim.

Ex. 2020 ¶ 37.

In its Reply, Petitioner argues that the *Nautilus* indefiniteness standard is inapplicable to proceedings before the Board under the Leahy-Smith America Invents Act (“AIA”).⁴ Pet. Reply 2–3. Instead, according to Petitioner, the standard set forth in *In re Packard*⁵ should be applied. *Id.* Petitioner argues that the Board’s proceedings under the AIA are “akin to

⁴ Pub. L. No. 112-29, 125 Stat. 284 (2011).

⁵ 751 F.3d 1307, 1313 (Fed. Cir. 2014).

reexamination proceedings, which apply the *Packard* test of indefiniteness.” *Id.* n.2 (citing *Cuozzo*, 136 S. Ct. at 2143–44). Petitioner notes that the Board similarly applies a different standard than the district courts when determining claim construction. *Id.* at 2–3 (citing *Cuozzo*, 136 S. Ct. at 2144–46). Alternatively, Petitioner argues that the claims are indefinite under either the *Nautilus* standard or the *Packard* standard. *Id.* at 3.

Petitioner contends that “determining whether a container is ‘filled,’ ‘substantially filled,’ or at some other point of fullness is a hopeless exercise contingent upon a user’s subjective desire.” *Id.* at 4. Petitioner argues that “the claims, specification and prosecution history of the ’066 Patent do not set forth objective boundaries for the terms ‘filled’ or ‘substantially filled.’” *Id.* at 5. Petitioner also challenges the testimony of Dr. Kudrowitz:

Tinnus’[s] reliance on the plain and ordinary meaning is misplaced where neither Tinnus nor its expert were able to articulate what “substantially filled” means. (Response, p. 69). [Dr.] Kudrowitz’s replacement of the word “substantially” with “approximately” clarifies nothing. (*Id.*, ¶ 32). Moreover, [Dr. Kudrowitz] is of the opinion that an expandable container is *always* “substantially filled with water,” because as you add more water, the container expands to contain the added volume. Specifically, [Dr.] Kudrowitz testified: “shortly before it starts expanding, it’s approximately full of water. While it’s expanding, it is also approximately full of water. When it bursts, it’s no longer a balloon.” (Ex#1019, 39:21–25).

Id. at 6.

At the oral argument, Patent Owner argued that the ordinary meaning of “filled” is “*completely filled*” (Tr. 36:19–20 (emphasis added)), and that, because the meaning of “filled” is clear on its face, looking to the Specification for guidance is unnecessary (*id.* at 36:4–14 (citing *Ancora Techs., Inc. v. Apple, Inc.*, 744 F.3d 732 (Fed. Cir. 2014))). Patent Owner

argued, in addition, that the term “filled” as applied to an elastic container does not necessarily mean that the container is filled to its bursting point. *Id.* at 37:18–24.

Rather, as contended by Patent Owner, the term “filled” refers to a *state* in which no more fluid (whether gas or liquid) can be placed into the container, and an elastic container filled to its bursting point represents only one such state. *Id.* at 37:12–39:2; *see also* PO Resp. 25 (arguing that “each of a plurality of elastic fasteners in relation to the other components in the ’066 Patent claims must allow each respective container to detach from its respective hollow tube when the hollow tubes are shaken in a state in which the containers are substantially filled with water”). Patent Owner explained its view that a skilled artisan can determine whether an elastic container is “substantially filled with water,” within the meaning of the claims, once the container is shaken from its hollow tube and sealed by its elastic fastener:

So, an expandable container isn’t mysterious, right? It has a -- especially once the elastic fastener has sealed the container, it has a fixed volume. There’s nothing moving in or out of that container once it’s sealed. And at that point, a person of ordinary skill in the art can examine that container and determine whether it is substantially filled with water.

Tr. 38:20–39:2.

Patent Owner asserted that “[j]ust because there’s a range of functionality . . . [j]ust because, again, in *Orthokinetics*,⁶ just because there’s a range of possibilities, that doesn’t render the claim indefinite.” *Id.* at 43:1–4. Patent Owner further argued:

⁶ *Orthokinetics, Inc. v. Safety Travel Chairs, Inc.*, 806 F.2d 1565, 1576 (Fed. Cir. 1986).

So, as long as there is a state in which a person of ordinary skill in the art can look at the balloon, and determine whether it's substantially filled, which just means approximately filled, is there a little bubble of air at the top or not; maybe. Is that substantially filled? If so, then the question is, were all of those other functions provided by the elastic fastener, did it hold the container on the tube when it was filled to that level? Check. Did it seal when it fell off? Check. Did it release when I shook it? Check.

That's the analysis.

Id. at 43:21–44:5.

2. *Analysis*

a. *We apply the test for indefiniteness approved by the Federal Circuit in Packard in this post-grant review AIA proceeding.*

In this post-grant review AIA proceeding, we apply the test for indefiniteness approved by the Federal Circuit in *Packard*, i.e., “a claim is indefinite when it contains words or phrases whose meaning is unclear.”⁷ We recognize that *Packard* involved a USPTO patent-examination matter. We also recognize that subsequent to the *Packard* decision, the Supreme Court in *Nautilus* enunciated a differently worded definiteness requirement

⁷ 751 F.3d at 1310, 1314; *see also id.* at 1313 (stating that “claims are required to be cast in clear—as opposed to ambiguous, vague, indefinite—terms”); Manual of Patent Examining Procedure (“MPEP”) § 2173.02(I) (Rev. 07.2015, Nov. 2015) (advising examiners that a rejection for indefiniteness is appropriate “after applying the broadest reasonable interpretation to the claim, if the metes and bounds of the claimed invention are not clear”).

in the context of patent infringement litigation.⁸ We do not understand *Nautilus*, however, to mandate the Board’s approach to indefiniteness in patent examination or reexamination matters⁹ or in AIA proceedings, in which the claims are interpreted under the broadest reasonable interpretation standard, and an opportunity to amend the claims is afforded.¹⁰ The test for indefiniteness approved in *Packard*, which is applied by the USPTO in patent examination, sets a threshold for indefiniteness that demands at least as much clarity, and potentially more clarity, than the *Nautilus* definiteness requirement. *See* MPEP § 2173.02(I).¹¹

⁸ *Nautilus*, 134 S. Ct. at 2129 (requiring “that a patent’s claims, viewed in light of the specification and prosecution history, inform those skilled in the art about the scope of the invention with *reasonable certainty*” (emphasis added)).

⁹ *See Packard*, 751 F.3d at 1323–24 (Plager, J., concurring) (recognizing and approving the reasons enumerated by the government why the agency uses “a lower threshold for ambiguity than a court’s” when reviewing a pending claim for indefiniteness).

¹⁰ We need not, and do not, decide in this case the approach to indefiniteness to be applied in Board proceedings where the BRI standard is inapplicable and an opportunity to amend is unavailable, such as when the patent being challenged has expired. *See In re CSB-System Int’l, Inc.*, 832 F.3d 1335, 1342 (Fed. Cir. 2016).

¹¹ “The [USPTO] construes claims by giving them their broadest reasonable interpretation during prosecution in an effort to establish a clear record of what the applicant intends to claim. Such claim construction during prosecution may effectively result in a lower threshold for ambiguity than a Court’s determination. *Packard*, 751 F.3d at 1323–24 [] (Plager, J., concurring). However, applicant has the ability to amend the claims during prosecution to ensure that the meaning of the language is clear and definite prior to issuance or provide a persuasive explanation (with evidence as

We determine that the test for indefiniteness that is applied in patent examination and reexamination matters, approved in *Packard*, should be applied in this post-grant review AIA proceeding, rather than the *Nautilus* requirement. The different approaches to indefiniteness before the PTO and the courts stem from the distinct roles that the PTO and the courts play in the patent system.¹² In AIA proceedings, as in patent examination and reexamination matters, applying the broadest reasonable interpretation standard, coupled with an opportunity to amend the claims, is an approach that is fair to the patent holder and protects the public. *See Cuozzo*, 136 S. Ct. at 2145–46; *Packard*, 751 F.3d at 1312–14. This approach serves to ensure precision in patent claims, thereby helping the public to understand the limits of the claims and keeping the rights afforded by patents within their legitimate scope. *See Cuozzo*, 136 S. Ct. at 2144–45; *Packard*, 751 F.3d at 1313. Accordingly, among the reasons supporting application of the *Packard*-approved indefiniteness test in this AIA proceeding are those recognized by the Supreme Court in *Cuozzo* as supporting use of the broadest reasonable interpretation standard in *inter partes* review AIA proceedings. *See Cuozzo*, 136 S. Ct. at 2143–2146. Of these, the most important is the opportunity to amend the claims to correct any ambiguity. *See id.* at 2145 (“The patent holder may, at least once in the process, make a motion to do just what he would do in the examination process, namely,

necessary) that a person of ordinary skill in the art would not consider the claim language unclear.”

¹² *See Packard*, 751 F.3d at 1325 (Plager, J., concurring) (stating that “unlike courts which have a full prosecution record to consider, the prosecution record before the USPTO is in development and not fixed during examination”).

amend or narrow the claim.”) (citation omitted); 35 U.S.C. § 326(d); 37 C.F.R. § 42.221. An applicant’s ability to clarify claim language through amendment was a significant reason why the Federal Circuit in *Packard* approved of the indefiniteness test recited in the MPEP (i.e., a “claim is indefinite when it contains words or phrases whose meaning is unclear”). *Packard*, 751 F.3d at 1313–14.

In the case before us, the indefiniteness issue centers on the phrase “a connecting force that is not less than a weight of one of the containers when substantially filled with water” recited in independent claim 1:

a plurality of elastic fasteners, each elastic fastener clamping a respective one of the plurality of containers to a corresponding hollow tube, and each elastic fastener configured to provide *a connecting force that is not less than a weight of one of the containers when substantially filled with water*, and to automatically seal its respective one of the plurality of containers upon detaching the container from its corresponding hollow tube, such that shaking the hollow tubes in a state in which the containers are substantially filled with water overcomes the connecting force and causes the containers to detach from the hollow tubes thereby causing the elastic fasteners to automatically seal the containers.

Ex. 1001, 6:39–51 (emphasis added). For the reasons that follow, we determine, applying the *Packard* indefiniteness test, that claim 1 is indefinite on several levels. Claims 2–6, 8, and 10–14 are indefinite as well, based on their dependency from claim 1.

b. Whether a container is “filled” depends, subjectively, on whether a desired size or volume has been reached.

First, with respect to the word “filled,” Patent Owner’s argument that “filled” means holding as much as can be contained—and *no less* (*see*

Tr. 36:19–20 (asserting that the ordinary meaning of “filled” is “completely filled”); Ex. 2020 ¶¶ 30–31 (explaining the meaning of “filled” in terms of a coffee mug filled “to its brim”))—is inconsistent with the Specification and the weight of the evidence. Nowhere does the Specification indicate that “filled” has such a narrow meaning. To the contrary, the Specification consistently teaches that whether a container is “filled” depends, subjectively, on whether a desired size or volume has been reached. *See, e.g.,* Ex. 1001, 3:48–51 (“After containers 18 have reached a *desired size or volume*, they may be detached from tubes 16. In one example embodiment, *filled* containers 18 may be detached by pulling them away from tubes 16.” (emphases added)); 4:6–9 (“In some embodiments, containers 18 may be marked with volumetric measurements, and fluid flow may be turned off when the fluid has *filled* containers 18 to a *desired volume*.” (emphases added)); 4:60–63 (“When containers 18 have reached a *desired size* and/or they are *filled* with the *desired volume* of fluid, they may be removed from tubes 16. They can be removed . . . by shaking them off.” (emphases added)); 5:43–46 (“When fluid *fills* container 18A to a *desired volume*, for example, as indicated by volumetric measurement marking 44, container 18A may be detached from tube 16A.” (emphases added)).

Patent Owner attempts to distinguish the above-cited statements in the Specification on the basis that they “refer to a *use* of the claimed device, not to the claimed structure defined by the functionality stated in Claim 1.” *See* PO Resp. 75. Patent Owner argues:

While a user of the claimed structure may fill a container to any desired volume he or she chooses, that is not the standard for infringement or indefiniteness. A POSA would understand that

the claimed limitation merely specifies an attribute of structure with functional language.

Id. (citing Ex. 2020 ¶ 34).

Patent Owner’s argument overlooks that the same word “filled” is employed both in the Specification and claim 1. Indeed, “claims should always be read in light of the specification and teachings in the underlying patent.” *Microsoft Corp.*, 789 F.3d at 1298 (quoting *In re Suitco Surface, Inc.*, 603 F.3d 1255, 1260 (Fed. Cir. 2010)). Patent Owner has not persuaded us that a person of ordinary skill in the art would disregard the broad meaning attributed to the word “filled” in the Specification when reading that same word in claim 1.

Patent Owner’s reliance on *Ancora* to avoid the teaching of the Specification is misplaced. *See* Tr. 36:4–14. In *Ancora*, the district court’s claim construction limited the term “program” to application programs, thereby excluding operating systems from the class of programs covered by the claimed method. 744 F.3d at 734. The district court’s narrow claim construction was erroneous, the Federal Circuit determined, because the ordinary meaning of the word “program,” in the context of the claimed invention, *indisputably* encompassed operating systems as well as application programs, and the intrinsic record did not show with sufficient clarity that the patentee had adopted a different definition or otherwise disclaimed that meaning. *Id.* at 734–37. Even so, the Federal Circuit did not ignore the specification, but instead explained that “[n]othing in the specification clearly narrows the term.” *Id.* at 735. Here, in distinction with *Ancora*, the ordinary meaning of “filled” is disputed, and the Specification sheds light on the meaning of that term in the context of the claimed invention.

Patent Owner also argues that objective boundaries for “substantially filled” can be found in the Specification and prosecution history, but the portions of the record on which Patent Owner relies do not elucidate the meaning of “filled.” *See* PO Resp. 67–68 (citing Ex. 2020 ¶ 26; Ex. 1001, 3:52–55; Ex. 2010, 154–155). Rather, the cited portions of the record pertain to the amount of “shaking” required to detach the containers from the hollow tubes and the upper limit of the strength of the elastic fastener. *See, e.g., id.* at 68 (citing Ex. 2010, 154–155 (the Examiner stating in the Notice of Allowability that “the language [of claim 1] beginning with ‘such that shaking . . .’ defines an *upper limit* of the connecting force and thus defines the elastic fastener in a way which distinguishes over Urspringer”) (emphasis by Patent Owner)). Contrary to Patent Owner’s argument, the Specification does not supply an objective standard for measuring the scope of the term “filled” or “substantially filled.”

The testimony of Dr. Kudrowitz as to the meaning of “filled” also is not persuasive. *See* Ex. 2020 ¶¶ 30–31. His testimony, for example, that “[a] coffee mug containing coffee, to its brim, is filled with coffee,” does not explain sufficiently how a skilled artisan would interpret the word “filled” in the context of the claimed invention. *See id.* ¶ 31. In particular, Dr. Kudrowitz does not explain clearly how this analogy applies to expandable containers. Nor does Dr. Kudrowitz offer any explanation of the statements in the Specification, discussed above, that appear to teach a subjective meaning of “filled.”

For example, Dr. Kudrowitz testifies that “[t]he defined functionality of Claim 1 is exemplified in the specification of the ’066 Patent.” *Id.* ¶ 45. Referring to the balloon embodiment depicted in Figure 2 (reproduced *supra*

in Section I.C) and quoting the statement in the Specification that “[w]hen containers 18 have reached a desired size and/or they are filled with the desired volume of fluid, they may be removed from tubes 16” (Ex. 1001, 4:60–62 (emphasis added)), Dr. Kudrowitz testifies that “[a] person having experience designing water balloons and filling devices for such balloons, or even a person merely having general experience with containers, including water balloons, would understand whether such containers are substantially filled with water.” Ex. 2020 ¶ 45. That testimony is conclusory and unpersuasive.¹³ Dr. Kudrowitz fails to explain how a person of ordinary skill in the art would interpret the words—“[w]hen containers 18 have reached a desired size and/or they are filled with the desired volume of fluid, they may be removed from tubes 16”—that he himself quotes.

Finally, neither Dr. Kudrowitz nor Patent Owner persuasively addresses the subjective meaning of “filled” indicated by dependent claim 6, which recites: “The apparatus of claim 1, wherein each container comprises a *volumetric measurement marking* providing a visual reference for *filling the container to a desired volume.*” Ex. 1001, 6:65–67 (emphasis added). The recitations in dependent claim 6 of “volumetric measurement markings” and “filling the container to a desired level” are strong indications that a “filled” container is not necessarily a “completely filled” container. Rather, as recited in dependent claim 6 and taught in the Specification, whether a container is “filled” depends, subjectively, on whether a desired size or volume (e.g., the level of a measurement marking) has been reached. *See, e.g.*, Ex. 1001, 4:6–9 (“In some embodiments, containers 18 may be marked

¹³ *See also* Ex. 2020 ¶¶ 24, 47 (also containing testimony that is conclusory and unpersuasive).

with *volumetric measurements*, and fluid flow may be turned off when the fluid has *filled containers 18 to a desired volume.*” (emphases added)); 5:43–46 (“When fluid *fills container 18A to a desired volume*, for example, as indicated by *volumetric measurement marking 44*, container 18A may be detached from tube 16A.” (emphases added)).

Patent Owner argues that the term “substantially filled” is analogous to the limitation at issue in *Orthokinetics*. See, e.g., Tr. 34:9–24. The limitation in *Orthokinetics* related to a wheel chair and recited that the front leg portion of the chair “is *so dimensioned* as to be insertable through the space between the doorframe of an automobile and one of the seats thereof.” *Id.* at 1575. The Federal Circuit held the “so dimensioned” limitation was not indefinite, noting that the claims required “that one desiring to build and use a travel chair must measure the space between the selected automobile’s doorframe and its seat and then dimension the front legs of the travel chair so they will fit in that particular space in that particular automobile.” *Id.* at 1576. The court also noted the fact that “a particular chair on which the claims read may fit within some automobiles and not others is of no moment.” *Id.* Here, Patent Owner argues that, similar to the limitation in *Orthokinetics*, “one could experiment and determine which elastic fastener to use.” Tr. 34:9–11. The difference between the limitation in *Orthokinetics* and the term “substantially filled” at issue in this case is that the limitation in *Orthokinetics* defined the dimension of the front leg of the wheel chair by reference to a well-defined reference area (i.e., the space between the doorframe and seat of an automobile). Here, the level of water in a “substantially filled” container is not ascertainable or measurable by reference to any objective standard.

For these reasons, we determine that the phrase “not less than a weight of one of the containers when substantially *filled* with water” (emphasis added) is unclear and indefinite. A person of ordinary skill in the art could not interpret the metes and bounds of the phrase so as to understand how to avoid infringement because neither claim 1 nor the Specification provides any objective standard for measuring the scope of the term “filled.”¹⁴ As such, the weight of a container “filled” with water depends, subjectively, on whether a desired size or volume has been reached.¹⁵

c. Expandable containers involve a second level of ambiguity.

Dr. Kudrowitz’s analysis of claim 1 as applied to an expandable container highlights a second level of ambiguity of the phrase “a connecting force that is not less than a weight of one of the containers when substantially filled with water.” As discussed below, neither claim 1 nor the Specification provides an objective standard for measuring the scope of that phrase as applied to an expandable container.

¹⁴ See, e.g., *Ex parte Brummer*, Appeal No. 87-3579, 12 USPQ2d 1653, 1655 (BPAI May 11, 1989) (holding that a claim to a recumbent bicycle reciting “said front and rear wheels so spaced as to give a wheelbase that is between 58 percent and 75 percent of the height of the rider that the bicycle was designed for” was indefinite because “whether the bicycle was covered by the claim would be determined not on the basis of the structural elements and their interrelationships, as set forth in the claim, but by means of a label placed upon the bicycle at the discretion of the manufacturer”).

¹⁵ Accordingly, we agree with Petitioner that “determining whether a container is ‘filled’ . . . is . . . contingent upon a user’s subjective desire.” See Pet. Reply 4.

At his deposition in this case, Dr. Kudrowitz testified that an expandable container is approximately filled with water over its entire range of expansion:

If you're adding water to a balloon and it starts expanding because of the water . . . shortly before it starts expanding, it's approximately full of water. While it's expanding, it is also approximately full of water. When it bursts, it's no longer a balloon.

Ex. 1019, 39:18–25. Thus, according to Dr. Kudrowitz's testimony, from the time that a balloon to which water is being added starts to expand, until it bursts, the balloon is approximately filled with water.

Patent Owner's Demonstrative Exhibit 53, reproduced below, illustrates Dr. Kudrowitz's testimony:

States of Being "substantially filled with water"

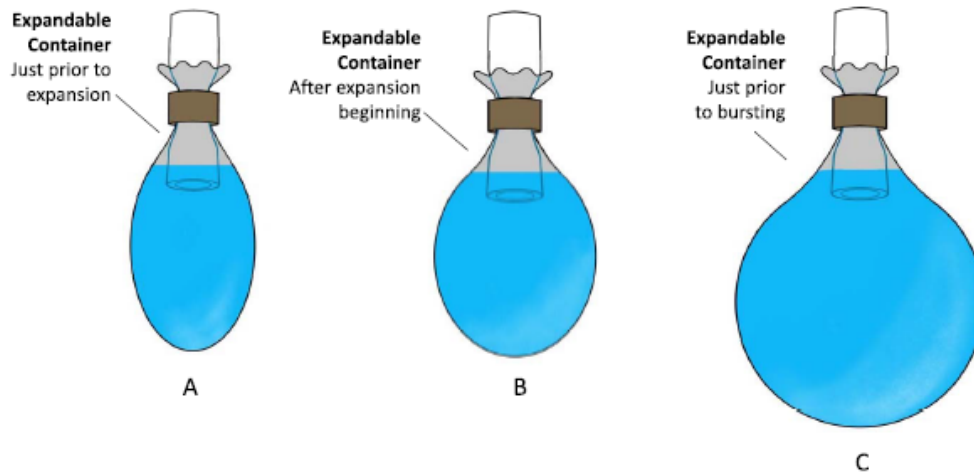

Patent Owner’s demonstrative exhibit depicts an expandable container (having the shape of a balloon) in three sequential states of being substantially filled with water—state (A) just prior to expansion, state (B) after expansion beginning, and state (C) just prior to bursting. Tr. 41:18–21. The exhibit purports to illustrate that the expandable container or balloon is “substantially filled with water” in all three states and, thus, over the entire range of expansion from (A) to (C).

As discussed above in Section II.B.1, Patent Owner contends based on Dr. Kudrowitz’s testimony that “filled” refers to a *state* in which no more fluid (whether gas or liquid) can be placed into a container, and an elastic container filled to its bursting point represents only one such state. Tr. 37:12–39:2; *see* PO Resp. 77 (citing Ex. 2020 ¶¶ 33–37). Patent Owner’s view is that a skilled artisan can determine whether an elastic container is “substantially filled with water” after the container is shaken from its hollow tube and sealed by its elastic fastener.

Assuming that a person of ordinary skill in the art would understand that a balloon or expandable container is “substantially filled with water” over a range of expansion, as Patent Owner contends,¹⁶ we determine that

¹⁶ We note, however, that no underlying facts or data in the record support the opinion of Dr. Kudrowitz that a balloon or expandable container does not start to expand before it is substantially full of water. *See* 37 C.F.R. § 42.65 (“Expert testimony that does not disclose the underlying facts or data on which the opinion is based is entitled to little or no weight.”). At the oral argument, Patent Owner was unable to explain adequately or persuasively why an elastic balloon could not begin to expand with the first few drops. Tr. 40:7–41:10. We further note that a more logical lower boundary for the putative range of states in which a balloon or expandable container is “substantially filled with water” might be the state in which a minimum

the phrase “not less than a weight of one of the containers when substantially filled with water” is, nevertheless, unclear and indefinite. Patent Owner’s demonstrative exhibit, reproduced above, illustrates the ambiguity. In state (C), just before bursting, the balloon or elastic fastener might not be strong enough to perform the required attachment and sealing functions due to the weight of the water in the container. At a lower level of expansion, however, in state (B), the same elastic fastener might be strong enough to provide “a connecting force that is not less than a weight of one of the containers when substantially filled with water,” as claim 1 requires. As such, *the same physical structure (including the elastic fastener)* could meet the claim requirements in state (B), when the expandable container is substantially filled with water, but not in state (C), when the expandable container *also* is substantially filled with water. Neither claim 1 nor the Specification provides an objective standard for measuring the scope of “a connecting force that is not less than a weight of one of the containers when substantially filled with water” as applied to an expandable container in this scenario. As such, those skilled in the art would not understand what is claimed when the claim is read in light of the Specification. *See Ex parte Miyazaki*, Appeal 2007-3300, 89 USPQ2d 1207, 2008 WL 5105055, at *4 (BPAI Nov. 19, 2008) (precedential) (citing *Orthokinetics*, 806 F.2d at 1576)); *see also Halliburton Energy Servs., Inc. v. M-I LLC*, 514 F.3d 1244, 1254–55 (Fed. Cir. 2008).¹⁷

volume of water substantially occupies the space or volume of the balloon or container, regardless of expansion.

¹⁷ “When a proposed construction requires that an artisan make a separate infringement determination for every set of circumstances in which the

In response to questioning from the panel at the oral argument, Patent Owner argued, citing *Orthokinetics*, that “just because there’s a range of possibilities, that doesn’t render the claim indefinite.” Tr. 43:2–4. Patent Owner further argued:

[A] person of ordinary skill in the art could easily take that fastener, and determine, assemble the structure and say, well, okay, when it releases, as long as it seals, then that would infringe, and that’s the standard. The standard isn’t to determine what all possibility could not infringe, that's not what’s required under Section 112. 112 requires that the patentee describe -- claim his invention, right?

He doesn’t have to say that all of these other things don’t infringe. And that’s what Petitioner wants from Patent Owner. Petitioner wants -- seems to have an idea that the functionality here is free for everyone to use, and that there’s -- they have some right to use that functionality because -- I don't know what it’s based on, but there was some line of questioning in our -- in the examination of our expert, along that line, about, well, how do you perform these functions without infringing the claim? Well, that’s not the standard.

Id. at 43:5–20.

Patent Owner’s argument confuses claim breadth with claim indefiniteness. Although a claim that encompasses a wide scope of subject matter or includes functional language may not be indefinite for that reason alone, a claim that “lacks the requisite minimum clarity to define the boundaries of the claims” is indefinite. *See Packard*, 751 F.3d at 1326 (Plager, J., concurring); *see also* MPEP § 2173.04 (stating that “[a] broad claim is not indefinite merely because it encompasses a wide scope of

[invention] may be used, and when such determinations are likely to result in differing outcomes (sometimes infringing and sometimes not), that construction is likely to be indefinite.”

subject matter . . . [b]ut a claim is indefinite when the boundaries of the protected subject matter are not clearly delineated and the scope is unclear”).

For these reasons, the phrase “a connecting force that is not less than a weight of one of the containers when substantially filled with water” as applied to an expandable container is unclear and indefinite.

d. Even if the term “substantially” means “approximately” as Patent Owner contends, there is no standard by which one of ordinary skill in the art can measure “substantially” so as to understand what is claimed.

Patent Owner argues that “[t]he addition of the term ‘substantially’ does not render the claim ambiguous or *per se* indefinite.” PO Resp. 72. Patent Owner further argues that “[i]t is well-established that relative terms such as ‘substantially’ do not render patent claims so unclear as to prevent a [POSA] from ascertaining the scope of the claim.” *Id.* at 72–73 (citing *Deere & Co. v. Bush Hog, LLC*, 703 F.3d 1349, 1359 (Fed. Cir. 2012) (citing *Ecolab, Inc. v. Envirochem, Inc.*, 264 F.3d 1358, 1867 (Fed. Cir. 2001); *Andrew Corp. v. Gabriel Elecs. Inc.*, 847 F.2d 819, 821 (Fed. Cir. 1988))). Patent Owner relies on the proposition that:

Expressions such as [“]substantially[”] are used in patent documents when warranted by the nature of the invention, in order to accommodate the minor variations that may be appropriate to secure the invention. Such usage may well satisfy the charge to [“]particularly point out and distinctly claim[”] the invention, 35 U.S.C. § 112, and indeed may be necessary in order to provide the inventor with the benefit of his invention.

Id. at 73 (quoting *Verve, LLC v. Crane Cams, Inc.*, 311 F.3d 1116, 1120 (Fed. Cir. 2002)).

Additionally, Patent Owner argues that

[t]he term [“]substantially[”] has been consistently construed as understood terms [sic] of degree. *See, e.g., Cordis Corp. v. Medtronic AVE, Inc.*, 339 F.3d 1352, 1360 (Fed. Cir. 2003) (“substantially uniform thickness” construed as “of largely or approximately uniform thickness”); *Playtex Prods. Inc. v. Procter & Gamble Co.*, 400 F.3d 901, 909 (Fed. Cir. 2005) (“substantially flattened surfaces” construed as “surfaces, including flat surfaces, materially flatter than the cylindrical front portion of the applicator”); *Apple, Inc. v. Samsung Elecs. Co., Ltd.*, 932 F. Supp. 2d 1076, 1083 (N.D. Cal. 2013) (finding the term “substantially centered” not indefinite.)

Id.

Patent Owner misapprehends the case law. As the Board stated in *Ex parte Lazzara*, “the case law requires some sort of standard by which one of ordinary skill in the art can measure a term of degree such as ‘substantially’ so as to understand what is claimed.” *Ex parte Lazzara*, Appeal No. 2007-0192, slip op. at 3 (BPAI Nov. 13, 2007) (informative).

While the standard for measuring a term of degree need not be defined with numerical specificity, the standard must be able to be derived from information in the patent regarding the purpose of the invention—or of the specific aspect of the invention to which the term of degree applies—as well as from experimentation.

Id. (citing *Seattle Box Co. v. Indus. Crating & Packing, Inc.*, 731 F.2d 818, 820–21, 826 (Fed. Cir. 1984)). In other words, “some standard must exist even if the ‘standard’ may be derived from information in the patent regarding the purpose of the invention—or of the specific aspect of the invention to which the term of degree applies—as well as from experimentation.” *Id.* at 12 (citing *Seattle Box*, 731 F.2d at 820–21, 826). In our Institution Decision, we informed Patent Owner of the significance of the absence of an objective standard, but Patent Owner did not identify

persuasively any such standard in the Patent Owner Response. *See* Dec. 12. Patent Owner also did not move to amend the claims to avoid any of the ambiguities that we identified in our Institution Decision.

Further, Patent Owner’s reliance on case law involving entirely separate patents and different technologies to define the term “substantially” in claim 1 of the ’066 Patent is misplaced. The Federal Circuit has explained that:

[a] particular term used in one patent need not have the same meaning when used in an entirely separate patent, particularly one involving different technology. . . . Even absent an express definition of a term in the specification or prosecution history, or a clearly established understanding of the meaning of the term in the art, the manner in which the term is used in the patent may dictate a definition that differs from the definition that would be given to the same term in a different patent with a different specification or prosecution history. *See Young Dental Mfg. Co. v. Q3 Special Prods., Inc.*, 112 F.3d 1137, 1143 (Fed.Cir.1997) (“The specification that is relevant to claim construction is the specification of the patent in which the claims reside.”).

Medrad, Inc. v. MRI Devices Corp., 401 F.3d 1313, 1318–19 (Fed. Cir. 2005).

Patent Owner contends that “[u]se of the term ‘substantially’ here does not by itself render the claim indefinite.” PO Resp. 73. Patent Owner further contends that “[t]he term ‘substantially’ should be viewed as a term of approximation, and, a POSA would interpret ‘substantially’ in this case to mean ‘approximately.’” *Id.* at 73–74 (citing Ex. 2020 ¶ 32). Patent Owner does not, however, direct us to any guidance in the claims or the Specification that would explain how much deviation from a completely filled container the term “substantially filled” allows.

The term “substantially filled” does not appear in the Specification. Further, as discussed above in Section II.B.2.a, the claims and Specification teach that whether a container is “filled” depends, subjectively, on whether a desired size or volume has been reached. As such, even assuming that “substantially” means “approximately” and “filled” means “completely filled,” as Patent Owner contends, there is no basis in the claims or the Specification for determining that a container is “substantially filled.” In these circumstances, without any standard for measuring “substantially,” experimentation would be of no assistance in determining the scope of the claims.

Dr. Kudrowitz’s testimony regarding the purpose of the phrase “substantially filled with water” is unpersuasive. *See* Ex. 2020 ¶¶ 33–37. Dr. Kudrowitz testifies that a POSA would understand that the purpose of that phrase is “to define the strength of the elastic fastener.” Ex. 2020 ¶ 33. Dr. Kudrowitz also testifies that “[t]he strength of the elastic fastener is defined by functionality” and that “[t]he claim places lower and upper bounds on the strength of the fastener.” *Id.* ¶ 34. As to the lower bound or “minimum strength,” Dr. Kudrowitz testifies that two functions are required: “First, the elastic fastener must be strong enough to attach a container to a hollow tube. Second, the elastic fastener must be strong enough to seal the container.” *Id.* ¶ 35. Dr. Kudrowitz opines that “[i]f the functions of the elastic fastener are achievable at a time when the container is in a state of having been substantially filled with water, then the selected elastic fastener would fall within the requirements of the claim.” *Id.* ¶ 37. That testimony, however, begs the question of the meaning of “substantially filled with water.”

We determine that the claims are unclear and indefinite for the additional reason that there is no standard by which one of ordinary skill in the art can measure “substantially” so as to understand what is claimed when the claims are read in light of the Specification.

III. MOTIONS TO EXCLUDE

In its Motion to Exclude (Paper 57), Patent Owner seeks to exclude Petitioner’s Exhibits 1031 and 1032. Paper 57, 1–3. We deny Patent Owner’s motion, as moot, because we did not consider the referenced exhibits in reaching our decision in this case.

In its Motion to Exclude (Paper 59), Petitioner seeks to exclude Patent Owner’s Exhibits 2016–2018, 2020 (¶ 84), 2024, 2025 (¶ 39), 2026 (¶ 39), 2027–2070, 2073, 2074, 2078, and 2085. Paper 59, 1–8. We deny Petitioner’s motion, as moot, because we did not consider the referenced exhibits and paragraphs in reaching our decision in this case.

IV. CONCLUSION

For the foregoing reasons, we determine that Petitioner has established, by a preponderance of the evidence, that claims 1–6, 8, and 10–14 are unpatentable for indefiniteness under 35 U.S.C. § 112(b).

Based on the indefiniteness of the claims, as set forth above, we do not reach Petitioner’s challenges under 35 U.S.C. § 103(a) to claims 1–4, 8, and 14 as obvious over Cooper, Saggio, and Lee, and claims 11–13 as obvious over Cooper, Saggio, Lee, and Berardi.

V. ORDER

In consideration of the foregoing, it is hereby:

ORDERED that claims 1–6, 8, and 10–14 of U.S. Patent No. 9,051,066 B1 are unpatentable.

This is a Final Written Decision. Parties to the proceeding seeking judicial review of the decision must comply with the notice and service requirements of 37 C.F.R. § 90.2.

PGR2015-00018
Patent 9,051,066 B1

PETITIONER:

Robert T. Maldonado
Tonia A. Sayour
Cooper & Dunham LLP
rmaldonado@cooperdunham.com
tsayour@cooperdunham.com

Eric J. Maurer
Boies, Schiller & Flexner LLP
emaurer@bsfllp.com

PATENT OWNER:

Garet K. Galster
Melissa S. Hockersmith
Brendan E. Squire
Dunlap Bennett & Ludwig, PLLC
ggalster@dbllawyers.com
mhockersmith@dbllawyers.com
bsquire@dbllawyers.com

Robert D. Spendlove
Laubscher, Spendlove & Laubscher, P.C.
rspendlove@laubscherlaw.com