

UNITED STATES PATENT AND TRADEMARK OFFICE

---

BEFORE THE PATENT TRIAL AND APPEAL BOARD

---

APPLE INC.,  
Petitioner,

v.

DSS TECHNOLOGY MANAGEMENT, INC.,  
Patent Owner.

---

Case IPR2015-00369  
Patent 6,128,290

---

Before JAMESON LEE, MATTHEW R. CLEMENTS, and  
CHARLES J. BOUDREAU, *Administrative Patent Judges*.

BOUDREAU, *Administrative Patent Judge*.

FINAL WRITTEN DECISION  
*35 U.S.C. § 318(a) and 37 C.F.R. § 42.73*

## I. INTRODUCTION

### A. Background

Petitioner Apple Inc. (“Apple”) filed a Petition (Paper 1, “Pet.”) to institute *inter partes* review of claims 1–4 of U.S. Patent No. 6,128,290 to Carvey (Ex. 1001, “the ’290 patent”). Patent Owner DSS Technology Management, Inc. (“DSS”) filed a Preliminary Response (Paper 8, “Prelim. Resp.”). On June 25, 2015, we instituted an *inter partes* review of claims 1–4 on one of two grounds of unpatentability presented in the Petition (Paper 9, “Dec.”).

After institution of trial, DSS filed a Patent Owner Response (Paper 17, “PO Resp.”), and Apple filed a Reply thereto (Paper 24, “Reply”). An oral hearing was held on March 15, 2016, and a transcript of the hearing is included in the record (Paper 39, “Tr.”).

We have jurisdiction under 35 U.S.C. § 6(c). This Final Written Decision is issued pursuant to 35 U.S.C. § 318(a) and 37 C.F.R. § 42.73.

Based on the record before us, and for the reasons that follow, we determine that Apple has demonstrated, by a preponderance of the evidence, that each of claims 1–4 of the ’290 patent is unpatentable.

### B. Related Matters

The ’290 patent has been the subject of two district court actions: *DSS Technology Management, Inc. v. Apple, Inc.*, No. 5:14-cv-05330-LHK (N.D. Cal.), and *DSS Technology Management, Inc. v. Lenovo (United States), Inc.*, No. 6:14-cv-00525-JDL (E.D. Tex.). Pet. 3–4; Paper 4, 2. IPR2015-00373 also involves claims of the ’290 patent and was argued together with this proceeding at the March 15, 2016, oral argument.

*C. The Instituted Ground*

We instituted a trial as to claims 1–4 of the '290 patent under 35 U.S.C. § 103(a) as unpatentable over U.S. Patent No. 5,241,542 to Natarajan et al. (Ex. 1003, “Natarajan”) and U.S. Patent No. 4,887,266 to Neve et al. (Ex. 1004, “Neve”). Dec. 13–21.

II. ANALYSIS

*A. The '290 Patent*

The '290 patent, titled “Personal Data Network,” issued October 3, 2000, from U.S. Patent Application No. 08/949,999 (Ex. 1005, 22–62, “the '999 application”). The '999 application was filed October 14, 1997, as a continuation-in-part of U.S. Patent Application No. 08/611,695 (Ex. 1006, 21–61, “the '695 application”), filed March 6, 1996, which matured into U.S. Patent No. 5,699,357 (Ex. 2001, “the '357 patent”). *See* Ex. 1001, 1:6–8.

The '290 patent relates to a data network for bidirectional wireless data communications between a host or server microcomputer unit and a plurality of peripheral units referred to as personal electronic accessories (PEAs). Ex. 1001, 1:11–14, 2:15–18. Among the objects of the invention is the provision of a data network that requires extremely low power consumption, “particularly for the peripheral units,” avoids interference from nearby similar systems, and is relatively simple and inexpensive to construct. *Id.* at 1:33–34, 1:39–45. Figure 1 of the '290 patent, reproduced below, is illustrative of the described wireless data network system.

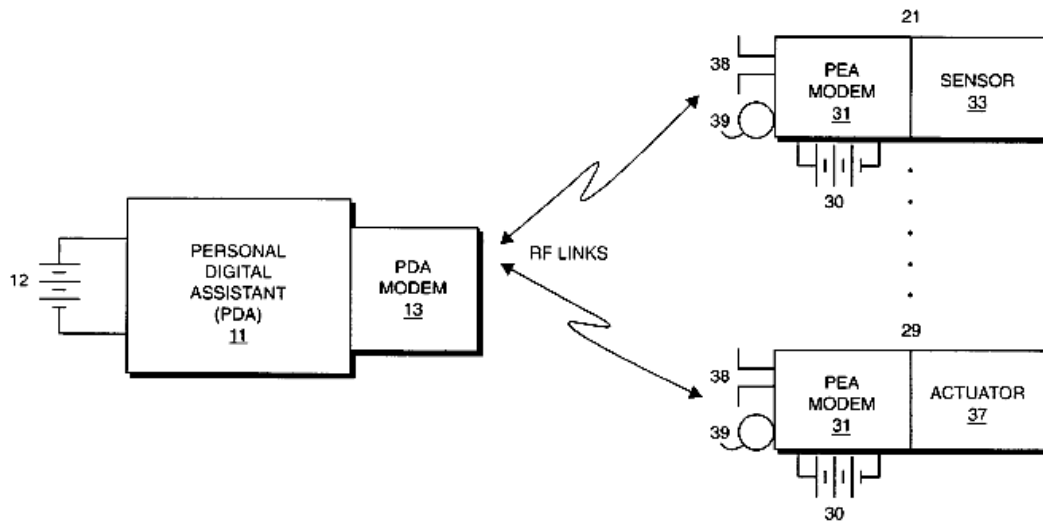

FIG. 1

Figure 1 is a block diagram of a wireless data network system linking a server microcomputer, referred to as personal digital assistant (PDA) 11, with a plurality of peripheral units, or PEAs, 21–29. *Id.* at 2:42–44, 2:66–3:15.

According to the '290 patent, “the server microcomputer unit and the several peripheral units which are to be linked are all in close physical proximity, e.g., within twenty meters, to establish, with very high accuracy, a common time base or synchronization.” *Id.* at 1:50–54. “Using the common time base, code sequences are generated which control the operation of the several transmitters in a low duty cycle pulsed mode of operation.” *Id.* at 1:57–59. “The server and peripheral unit transmitters are energized in low duty cycle pulses at intervals which are determined by a code sequence which is timed in relation to the synchronizing information initially transmitted from the server microcomputer.” *Id.* at 2:35–39. “The low duty cycle pulsed operation both substantially reduces power consumption and facilitates the rejection of interfering signals.” *Id.* at 1:59–

61. “In the intervals between slots in which a PEA is to transmit or receive, all receive and transmit circuits are powered down.” *Id.* at 4:6–8.

*B. Illustrative Claim*

Claim 1, the sole independent claim among the challenged claims, is reproduced below. Challenged claims 2–4 depend directly or indirectly from claim 1.

1. A data network system for effecting coordinated operation of a plurality of electronic devices, said system comprising:

a server microcomputer unit;

a plurality of peripheral units which are battery powered and portable, which provide either input information from the user or output information to the user, and which are adapted to operate within short range of said server unit;

said server microcomputer incorporating an RF transmitter for sending commands and synchronizing information to said peripheral units;

said peripheral units each including an RF receiver for detecting said commands and synchronizing information and including also an RF transmitter for sending input information from the user to said server microcomputer;

said server microcomputer including a receiver for receiving input information transmitted from said peripheral units;

said server and peripheral transmitters being energized in low duty cycle RF bursts at intervals determined by a code sequence which is timed in relation to said synchronizing information.

Ex. 1001, 11:61–12:18.

*C. Claim Construction*

The '290 patent expired on March 6, 2016, twenty years from the filing date of the '695 application from which the '290 patent claims

priority. 35 U.S.C. § 154(a)(2). We construe expired patent claims according to the standard applied by the district courts. *See In re Rambus Inc.*, 694 F.3d 42, 46 (Fed. Cir. 2012). Specifically, we apply the principles set forth in *Phillips v. AWH Corp.*, 415 F.3d 1303, 1312–17 (Fed. Cir. 2005) (en banc). “In determining the meaning of the disputed claim limitation, we look principally to the intrinsic evidence of record, examining the claim language itself, the written description, and the prosecution history, if in evidence.” *DePuy Spine, Inc. v. Medtronic Sofamor Danek, Inc.*, 469 F.3d 1005, 1014 (Fed. Cir. 2006) (citing *Phillips*, 415 F.3d at 1312–17). Only those terms that are in controversy need to be construed, and only to the extent necessary to resolve the controversy. *Vivid Techs., Inc. v. Am. Sci. & Eng’g, Inc.*, 200 F.3d 795, 803 (Fed. Cir. 1999).

The words of a claim are generally given their ordinary and customary meaning, and that is the meaning the term would have to a person of ordinary skill at the time of the invention, in the context of the entire patent including the specification. *See Phillips*, 415 F.3d at 1312–13. Claims are not interpreted in a vacuum but are a part of and read in light of the specification. *See Slimfold Mfg. Co. v. Kinkead Indus., Inc.*, 810 F.2d 1113, 1116 (Fed. Cir. 1987). Although it is improper to read a limitation from the specification into the claims (*In re Van Geuns*, 988 F.2d 1181, 1184 (Fed. Cir. 1993)), the claims still must be read in view of the specification of which they are a part. *See Microsoft Corp. v. Multi-Tech Sys., Inc.*, 357 F.3d 1340, 1347 (Fed. Cir. 2004).

If the applicant for patent desires to be its own lexicographer, the purported definition must be set forth in either the specification or prosecution history. *CCS Fitness, Inc. v. Brunswick Corp.*, 288 F.3d 1359,

1366 (Fed. Cir. 2002). And such a definition must be set forth with reasonable clarity, deliberateness, and precision. *In re Paulsen*, 30 F.3d 1475, 1480 (Fed. Cir. 1994).

Apple asked us in its Petition to construe two phrases: “within short range of said server unit,” as recited in claim 1, and “code sequence,” as recited in claims 1 and 3. Pet. 9–11. DSS responded to Apple’s proposed construction of only the first of these phrases in its Preliminary Response, and additionally asked us to construe “energized in low duty cycle RF bursts,” also recited in claim 1. Prelim. Resp. 18–21. DSS proposed, in particular, that the phrase “energized in low duty cycle RF bursts” be given its plain and ordinary meaning, or alternatively, in the event of any ambiguity, that it should be construed as “a pulsed operation that substantially reduces power consumption and facilitates the rejection of interfering signals.” *Id.* at 20 (boldface and italics omitted).

In our Decision on Institution, we construed the phrase “within short range” to mean “within a range in which the accuracy of synchronization is not appreciably affected by transit time delays, including at least the range of within 20 meters,” but concluded that it was not necessary for our determination of whether to institute *inter partes* review of claims 1–4 of the ’290 patent to construe expressly the phrases “code sequence” and “energized in low duty cycle RF bursts.” Dec. 7–10. Because the ’290 patent had not yet expired at the time of our Decision on Institution, we interpreted the claims under the broadest reasonable interpretation standard. Dec. 6–7; *see* 37 C.F.R. § 42.100(b); Office Patent Trial Practice Guide, 77 Fed. Reg. 48,756, 48,766 (Aug. 14, 2012); *In re Cuozzo Speed Techs.*,

*LLC*, 778 F.3d 1271, 1278–81 (Fed. Cir. 2015), *cert. granted sub nom. Cuozzo Speed Techs. LLC v. Lee*, 136 S. Ct. 890 (mem.) (2016).

Notwithstanding that we now apply the *Phillips* standard, our construction now for “within short range” is the same as our construction in the Decision on Institution. Neither party now challenges that construction or our determination in the Decision on Institution that “code sequence” does not require express construction. Based on DSS’s Patent Owner Response, Apple’s Reply, and the arguments presented at oral argument, however, the construction of the phrase “energized in low duty cycle RF bursts” is a central issue in this proceeding.

*“energized in low duty cycle RF bursts”*

Outside of the claims, the ’290 patent recites the phrase “low duty cycle” four times, as emphasized below:

The data network disclosed herein utilizes *low duty cycle* pulsed radio frequency energy to effect bidirectional wireless data communication between a server microcomputer unit and a plurality of peripheral units . . . . By establishing a tightly synchronized common time base between the units and by the use of sparse codes, timed in relation to the common time base, low power consumption and avoidance of interference between nearby similar systems is obtained.

Ex. 1001, Abst.

Using the common time base, code sequences are generated which control the operation of the several transmitters in a *low duty cycle* pulsed mode of operation. The *low duty cycle* pulsed operation both substantially reduces power consumption and facilitates the rejection of interfering signals.”

*Id.* at 1:57–61.

The server and peripheral unit transmitters are energized in *low duty cycle* pulses at intervals which are determined by a code



sequence which is timed in relation to the synchronizing information initially transmitted from the server microcomputer.

*Id.* at 2:35–39.

In its Patent Owner Response, DSS contends that a person of ordinary skill in the art would have understood the “duty cycle” of the server transmitter as “the ratio of actual duration during which the server transmitter is energized to the total duration designated for outbound transmissions.” *Id.* at 10 (emphasis omitted). DSS contends that understanding is consistent with deposition testimony provided by Apple’s expert, Dr. Jack Duane Grimes (*Id.* at 10–11 (citing Ex. 2015 (“Grimes Depo. Tr.”), 41:7–9 (“The low-duty cycle refers to the ratio of the time spent transmitting versus the time spent nontransmitting.”), 31:10–12 (“Low-duty cycle tells you that most of the time there’s nothing being sent. And when there is something being sent, that’s what’s called a burst.”), 46:12–15 (“[T]he key thing is that the burst is small—the time it takes is small relative to the overall time that the transmitter could have been transmitting.”))). Citing both Dr. Grimes’s deposition testimony and the declaration of its own expert, Robert Dezmelyk, DSS further contends that “the duty cycle of the server transmitter must be calculated over the total duration designated for the outbound transmissions,” and that “[t]ime slots designated for the inbound data traffic are not taken into account because the server transmitter could not have been transmitting during these time slots.” *Id.* at 11 (citing Ex. 2015, 60:19–22; Ex. 2016 (“Dezmelyk Decl.”) ¶¶ 23, 27). DSS concludes, “[u]nder the broadest reasonable interpretation, a [person of ordinary skill in the art] would have understood that a server transmitter is energized in a low duty cycle when the server transmitter is energized for

less than ten percent (10%) of the total duration designated for outbound transmissions.” *Id.*<sup>1</sup>

DSS contends the “less than ten percent” range is consistent with the Specification of the ’290 patent, including an example in which “a maximum of three RF bursts can occur” for outbound transmissions in sections that each include sixty-four slots, and another example in which transmitted synchronization beacons are described as consisting of eight RF bursts spread out over 252 slots. PO Resp. 11–12 (citing Ex. 1001, 7:22–33). According to DSS, the first example results in the server transmitter being energized for 4.688% (i.e., 3/64) of the transmission period, while in the second example, the server transmitter is energized in a duty cycle of 3.175% (i.e., 8/252). *Id.* at 12. DSS also cites five patents (Exs. 2004–2008) that it contends to be the first five “relevant” results “obtained on Google Patents through the query: ‘low duty cycle e.g.’ & network & percent” (*id.* at 12–13, 12 n.1, Table 1).<sup>2</sup> Those patents include exemplary “low duty cycle” ranges from “e.g., 0.5 percent” (Ex. 2006, 8:3) to “e.g., at an about 10 percent . . . duty cycle” (Ex. 2008, 10:5–6).

As to the phrase “RF bursts,” DSS contends that “a [person of ordinary skill in the art] would have understood the phrase ‘RF bursts’ to mean ‘*a short period of intense activity on an otherwise quiet data channel.*’” PO Resp. 13 (citing definition of “burst” from CHAMBERS DICTIONARY OF SCI. & TECH. 155 (1999) (Ex. 2009)). DSS asserts that this

---

<sup>1</sup> DSS and Apple both confirmed during the oral hearing that their respective claim construction proposals for “low duty cycle” would be no different under the *Phillips* standard, as opposed to the broadest reasonable interpretation standard. Tr. 28:23–29:1, 39:7–11.

<sup>2</sup> DSS does not explain its criteria for determining “relevance.”

construction is consistent with Dr. Grimes’s deposition testimony that “the key thing is that the burst is small—the time it takes is small relative to the overall time that the transmitter could have been transmitting” and with the ’290 patent’s illustration of 2  $\mu$ sec burst slots. *Id.* at 13–14 (citing Ex. 2015, 34:2–8, 46:12–15; Ex. 1001, Fig. 6).

In its Reply, Apple responds that a “low duty cycle” of a transmitter should simply be interpreted as the transmitter being designed to be on only to satisfy the data communication needs over the communication cycle of the system. Reply 22. According to Apple, “DSS’s proposed claim construction that ‘low duty cycle’ is less than 10% is arbitrary and unduly narrow.” *Id.* at 20 (emphasis omitted). Apple contends that “[t]he ‘examples’ that DSS cites in Table 1 are cherry-picked results from a search premised on finding examples by including ‘e.g.’ in the search string,” that “none of these references are contemporaneous with the ’290 patent’s filing date,” and that one of those examples even “contradicts the proposed construction of ‘*less than* ten percent,’ providing a ‘low duty cycle, e.g., *at an about* 10 percent (10%) duty cycle.” *Id.* at 21 (quoting Ex. 2008, 10:5–6). Apple also contends that the deposition testimony of DSS’s expert undermines DSS’s proposed construction, as “Mr. Dezmelyk admits that the term ‘low duty cycle’ itself does not require an upper bound at 10%.” *Id.* (citing Ex. 1011 (“Dezmelyk Depo. Tr.”), 78:2–6).

Apple also points out that claim 8 of the ’357 patent (i.e., the parent of the ’290 patent), which was cited by Mr. Dezmelyk during his deposition as further support for the “10% limit,” recites “said low duty cycle pulses comprise chips within the respective code sequences such that a transmitter is energized [*sic*] less than 10% of the time during an allocated time slot.”

Reply 22. According to Apple, “[b]ecause claim 8 depends ultimately from independent claim 6, it is *narrower* than the independent claim, meaning that the ’357 patent contemplates a ‘low duty cycle’ *greater than* 10%.” *Id.*

In the oral hearing, DSS retreated from insisting that “low duty cycle” should be limited to a duty cycle of “less than ten percent.” While maintaining that “[l]ow duty cycle is a term of art” and that “[i]n the context of wireless communications, 10 percent is a reasonable number,” DSS conceded, “there is no hard value for the numbers.” Tr. 48:6–7, 48:22, 49:16–17. DSS asserted: “Anything below 10 percent is low duty cycle. Anything over 10 percent would be considered high duty cycle and—or at least it would not be considered a low duty cycle in the context of wireless communications technology.” *Id.* at 50:22–25. DSS additionally suggested that a person of ordinary skill in the art would understand that, if there were more data than could be transmitted in three of sixty-four slots, the transmission of the data would be held by the transmitter for future frames, and that “low duty cycle” operation requires “kicking off mobile units” and introducing “additional complexity and additional inefficiency,” merely so that a server transmitter can be depowered for the majority of a duty cycle regardless of whether there is more data waiting to be transmitted (*see id.* at 61:13–62:2, 71:9–72:5).

As an initial matter, we understand an “RF burst” to be “a short period of intense RF transmission activity on an otherwise quiet data channel,” consistent with DSS’s proposal (*see* PO Resp. 13). That understanding is supported by the ’290 patent and other evidence of record (*see* Ex. 1001, Fig. 1; Ex. 2009; Ex. 2015, 34:2–8, 46:12–15), and Apple does not provide any contrary argument.

Nonetheless, we are unpersuaded by DSS's arguments concerning the proper interpretation of "low duty cycle." First, we agree with Apple that the term "duty cycle" should be calculated based on the total time it takes a system to go through a cycle of communication (*see* Reply 22–23), and is not limited to "the total duration designated for outbound transmissions," as asserted by DSS (*see* PO Resp. 10) (emphasis omitted). This interpretation is consistent with the Specification. *See* Ex. 1001, 11:46–51 ("Further, the utilization of low duty cycle pulse mode transmission particularly with the employment of uncorrelated codes in a TDMA context, leads to very low power consumption since the transmitters and receivers in each PEA are powered for only a small percentage of *the total time*."). We also agree with Apple that "the data requirements for the master station to broadcast to the peripherals change[], and the data requirements for the peripherals to transmit back to the master station change over time." Tr. 9:4–8.

Accordingly, we understand the "duty cycle" of a transmitter to be the average ratio of the durations during which the transmitter is energized to the duration of communication cycles over the course of network operation.

We also agree with Apple that "low duty cycle" should not be limited to a duty cycle of less than 10% or to any other hard limit (Reply 20–22), and instead conclude, on this record, that "energized in low duty cycle RF bursts" simply means that a transmitter is not energized continuously over the course of network operation, but is depowered during at least two time periods of each communication cycle: first, in time slots in which the unit that includes the transmitter is assigned to receive data; and second, in time slots, if any, when the unit is assigned to transmit data but has no data to transmit.

As DSS conceded at the oral hearing, there is “no hard value” recited in the ’290 patent or elsewhere on the record (Tr. 49:16–17), and we are not persuaded on this record that we should infer from the examples in the ’290 patent that Applicant intended thereby to limit the meaning of “low duty cycle” to transmitting in just three of sixty-four or eight of 252 time slots reserved for transmission, or anything on that order (*see* PO Resp. 12). We also find that DSS’s suggestions regarding “kicking off” of mobile units and introduction of “complexity and “inefficiency” (*see* Tr. 61:13–62:2, 71:9–72:5) are inappropriate because they are new arguments raised for the first time at oral argument. Thus, those new arguments are not considered. *See Apple Inc. v. e-Watch, Inc.*, Case IPR2015-00412, slip op. at 40–41 (PTAB May 6, 2016) (Paper 50) (declining to consider arguments raised for the first time at oral argument).

We also are not persuaded by DSS’s sampling in its Patent Owner Response of five unrelated patents (i.e., Exs. 2004–2008) that, by virtue of their use of the abbreviation “e.g.,” explicitly provide only *examples* of low duty cycles (*see* Ex. 2002 (Black’s Law Dictionary, definition of “e.g.”)). PO Resp. 12–13. Indeed, although there may not be any evidence of record that the definition of “duty cycle” changed in the years between the filing date of the application for the ’290 patent and the filing dates of the applications that issued as Exhibits 2004–2008 (*see* Tr. 50:5–7), the fact that none of those references predates the ’290 patent casts doubt upon the weight to which that evidence is entitled in showing how a person of ordinary skill in the art would have understood low duty cycle in the context of the ’290 patent (*see* Reply 21).

In view of the foregoing, on the record before us, we conclude that the phrase “energized in low duty cycle RF bursts” means “energized, in short periods of intense RF transmission activity on an otherwise quiet data channel, only to the extent required to satisfy the data transmission needs over the course of a communication cycle.”

*D. Obviousness of Claims 1–4 over Natarajan and Neve*

Apple contends that claims 1–4 of the ’290 patent are unpatentable under 35 U.S.C. § 103(a) as obvious over the combination of Natarajan and Neve.

A claim is unpatentable under 35 U.S.C. § 103(a) if the differences between the claimed subject matter and the prior art are “such that the subject matter as a whole would have been obvious at the time the invention was made to a person having ordinary skill in the art to which said subject matter pertains.” We resolve the question of obviousness on the basis of underlying factual determinations, including: (1) the scope and content of the prior art; (2) any differences between the claimed subject matter and the prior art; (3) the level of skill in the art; and (4) objective evidence of nonobviousness, i.e., secondary considerations.<sup>3</sup> *See Graham v. John Deere Co.*, 383 U.S. 1, 17–18 (1966).

In an obviousness analysis, some reason must be shown as to why a person of ordinary skill would have combined or modified the prior art to achieve the patented invention. *See Innogenetics, N.V. v. Abbott Labs.*, 512 F.3d 1363, 1374 (Fed. Cir. 2008). A reason to combine or modify the prior art may be found explicitly or implicitly in market forces, design

---

<sup>3</sup> The record does not contain any evidence of secondary considerations.

incentives, the “interrelated teachings of multiple patents,” “any need or problem known in the field of endeavor at the time of invention and addressed by the patent,” or the background knowledge, creativity, and common sense of the person of ordinary skill. *Perfect Web Techs., Inc. v. InfoUSA, Inc.*, 587 F.3d 1324, 1329 (Fed. Cir. 2009) (quoting *KSR Int’l Co. v. Teleflex Inc.*, 550 U.S. 398, 418–21 (2007)).

1. *Scope and Content of the Prior Art*

a. *Overview of Natarajan*

Natarajan is directed to power conservation in wireless communication, particularly battery efficient operation of wireless link adapters of mobile computers (also referred to, *inter alia*, as battery powered computers, hand held or laptop computers, mobile units, and mobile stations) as controlled by multiaccess protocols used in wireless communication. Ex. 1003, Abst., 1:7–13, 2:32. Figure 2 of Natarajan is reproduced below.

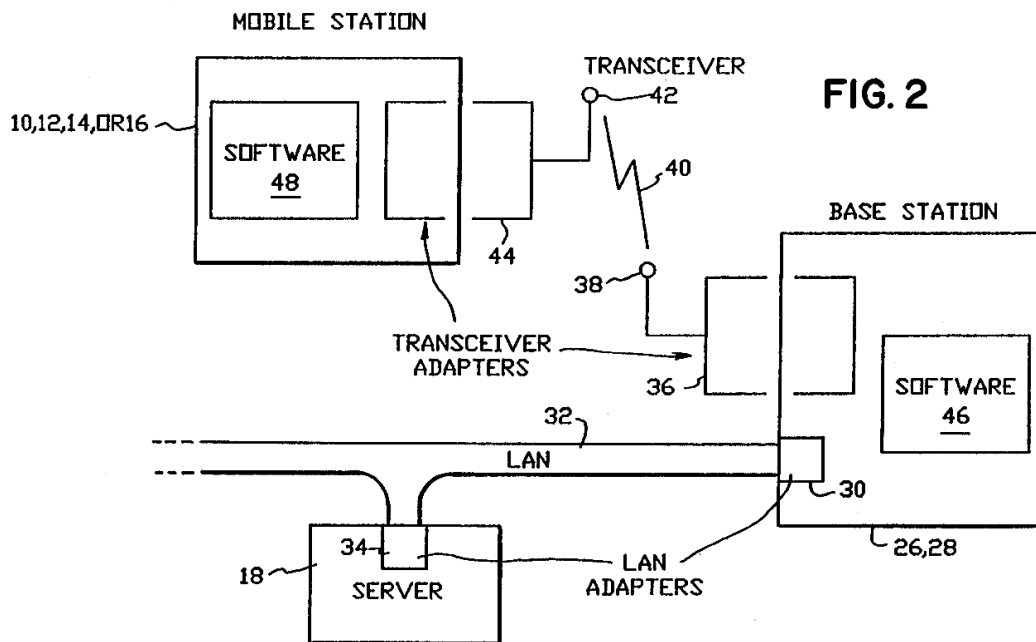



Figure 2 is a block diagram of a digital data communication system of the type in which Natarajan's invention is implemented, illustrating the basic components of a mobile station and a base station. *Id.* at 1:67–2:3. As depicted in Figure 2, mobile stations 10, 12, 14, and 16 communicate with gateways (i.e., base stations 26, 28) connected with server 18, via wireless transceivers adapters 36, 44. *Id.* at 2:32–39, 2:51–52, 2:58–59, 2:65–67.

According to Natarajan:

The scheduled access multiaccess protocol is implemented to effectively conserve battery power by suitable control of the state of the controller, the transmitter and receiver units at the wireless link adapter by scheduling when the adapter is in a normal running mode, or a standby mode in which power is conserved.

*Id.* at Abst.; *see also id.* at 3:66–4:1.

Natarajan discloses that “[a] desirable solution is one in which the transmitter (or receiver) consumes power only when it is actively transmitting a message (or actively receiving a message).” *Id.* at 4:3–6. Natarajan further discloses that the scheduled multiaccess protocol divides time into “fixed-length frames, and frames are divided into slots.” *Id.* at 4:20–23. The frames are divided into subframes for transmission of data from the base station to mobile units (outbound traffic) as well as transmission of data from mobile units to the base station (inbound traffic). *Id.* at 4:27–38. According to Natarajan, at least one slot is assigned to each mobile computer designated to communicate with the base station. *Id.* at 10:26–29. The battery power of the wireless link adapter for a given mobile computer is turned on to full power during the at least one assigned slot, and the battery power of the wireless link adapter is substantially reduced during the remaining time slots. *Id.* at 10:29–37.

With respect to outbound traffic, Natarajan discloses that the base station broadcasts a header that includes a list of mobile users that will be receiving data packets from the base station in the current frame, the order in which the mobile users will receive the data packets, and the bandwidth allocated to each user. *Id.* at 4:45–53. According to Natarajan, a mobile unit that is not included in the header from the base station can turn its receiver “OFF” for the duration of the current subframe. *Id.* at 4:64–67. Additionally, the adapter of each receiving mobile unit can compute exactly when it should be ready to receive packets from the base station by adding up the slots allocated to all receiving units that precede it, power “ON” during that time slot to receive its data, and go back to sleep for the remainder of the subframe. *Id.* at 4:67–5:6.

For inbound traffic, Natarajan similarly discloses that the base station broadcasts a header that includes an ordered list of users that will be allowed to transmit packets to the base station in the current frame and the bandwidth allocated to each. *Id.* at 5:9–19. Using the information regarding the number of packets that each user can transmit, each mobile unit can compute exactly when it should begin its transmission. *Id.* at 5:20–22. Once each mobile station computes its exact time for transmission, it can shut both its transmitter and receiver “OFF” until the designated time, and then turn “ON” and transmit for a fixed period of time whose duration depends on the number of slots allocated to it. *Id.* at 5:23–29.

*b. Overview of Neve*

Neve is directed to a communication system able to provide multiple path communication between a plurality of stations operating on a single channel. Ex. 1004, Abst. Neve discloses that one station, which is

physically similar to the others but operates a different stored program, may be designated the “master” station and provides synchronization signals for all of the other stations (referred to as “‘slave’ stations”) and controls access of the stations to the single radio channel. *Id.* at 4:10–15.

According to Neve, the stations are synchronized and a cyclically repeating series of time slots is defined. *Id.* at Abst. One time slot in each cycle is reserved for the transmission of synchronization information by the master station for reception by the slave stations and for maintaining synchronization therein. *Id.* Another time slot is reserved for any slave station to transmit a message indicating that it needs to communicate to another station, such indication preferably being by transmitting its own pre-assigned address code. *Id.* The remaining time slots are used for transmitting address information and data. *Id.*

Neve discloses that when data transfer is not taking place, the described devices can enter a lower power consumption state. *Id.* at 2:13–16. The system is designed automatically to re-enter the data transfer condition when either a signal is received from the device indicative of the need to transmit data or a predetermined code signal is received by the receiver circuit indicative of the need to receive data. *Id.* at 2:19–24. Neve discloses that the receiver has very low power consumption because only the internal timing circuitry is energized continuously, whereas the rest of the receiving circuit is energized only when its assigned time slot occurs. *Id.* at 2:39–41. More particularly, the receiver circuit includes a low power timing circuit that operates to energize the rest of the receiver circuit only for the time slot in which its address may occur and for the synchronization time slot, thereby enabling it to maintain synchronization with low power

consumption. *Id.* at 4:43–48. Neve similarly discloses that the interface circuit is arranged to energize the transmitter circuit only when transmission is required. *Id.* at 2:45–47.

2. *Level of Ordinary Skill in the Art*

We determine that no express finding with regard to the level of ordinary skill in the art is necessary in this proceeding, as the level of ordinary skill in the art is reflected by the prior art of record. *See Okajima v. Bourdeau*, 261 F.3d 1350, 1355 (Fed. Cir. 2001); *In re GPAC Inc.*, 57 F.3d 1573, 1579 (Fed. Cir. 1995); *In re Oelrich*, 579 F.2d 86, 91 (CCPA 1978).

3. *Differences Between the Prior Art and Claims 1–4;  
Reasons to Combine*

a. *Uncontested Claim Limitations*

The features of Natarajan and Neve are summarized above. Regarding claim 1, we have considered Apple’s evidence, including Dr. Grimes’s testimony (Ex. 1008 ¶¶ 89–126), presented at pages 39–59 of the Petition, and make the following findings regarding matters not disputed in DSS’s Patent Owner Response:

- i. Natarajan and Neve are from the same field of endeavor—wireless network communication systems (*see* Ex. 1003, Abst.; Ex. 1004, Abst.);
- ii. Both Natarajan and Neve disclose a data network system for effecting coordinated operation of a plurality of electronic devices, as recited in claim 1 (*see* Ex. 1003, 1:67–68, 6:48–54, Fig. 1; Ex. 1004, 4:6–9, Fig. 9);
- iii. Both Natarajan and Neve are concerned with conserving battery power of battery powered, portable, wireless

- devices (*see* Ex. 1003, Abst., 1:16–21; Ex. 1004, 1:29–34, 2:48–59);
- iv. Both Natarajan and Neve disclose a server that communicates with a plurality of “peripheral units,” where each device has an RF transmitter and receiver (*see* Ex. 1003, Abst., 2:40–45, Figs. 1, 2; Ex. 1004, Abst., 3:64–66, 4:10–15, Figs. 1, 4, 5, 9);
  - v. Natarajan’s “base station” and Neve’s “master station” are “server microcomputer[s] incorporating an RF transmitter for sending commands . . . to . . . peripheral units,” as recited in claim 1 (*see* Ex. 1003, 2:51–58, 3:18–21, 4:20–5:19, 6:48–54, Figs. 2, 3; Ex. 1004, 3:26–28, 3:59–63, 7:46–49, Figs. 1, 3);
  - vi. Neve discloses that the server unit (“master station”) sends “synchronizing information” to peripheral units, as recited in claim 1 (*see* Ex. 1004, Abst., 4:10–13, Fig. 2);
  - vii. Natarajan’s “mobile units” and Neve’s “slave units” are “peripheral units which are battery powered and portable, which provide either input information from the user or output information to the user, . . . which are adapted to operate within short range of said server unit,” and which “each includ[e] an RF receiver for detecting said commands and synchronizing information and including also an RF transmitter for sending input information from the user to said server microcomputer,” as recited in claim 1 (*see* Ex. 1003, Abst., 1:39–43, 2:1–3, 2:48–60,

- 2:65–67, 3:28–30, 3:50–51, 4:30–38, 4:67–5:2, 5:20–26, 6:17–21, 6:32–34, 6:41–44, Figs. 1–3; Ex. 1004, Abst., 1:10–15, 1:34–40, 3:59–63, 7:46–49);
- viii. Neve discloses that the server (“master unit”) is physically similar to the peripheral units (“slave units”) but operates a different stored program (*see* Ex. 1004, 2:49–55, 4:10–15);
- ix. Natarajan and Neve reduce power consumption in similar ways, by scheduling transmission time slots and having devices operate in a low power mode when they are not transmitting or receiving data (*see* Ex. 1003, Abst., 3:66–4:7; Ex, 1004, Abst., 2:35–41);
- x. Natarajan and Neve each disclose “peripheral transmitters being energized in low duty cycle RF bursts at intervals determined by a code sequence,” as recited in claim 1; in particular, Natarajan discloses that “[s]cheduled access multiaccess protocols can be implemented to effectively conserve battery power by suitable control of the state of transmitter and receiver units at the portable units (i.e., by scheduling when they should be turned ON or OFF),” that “the transmitter (or receiver) consumes power only when it is actively transmitting a message (or actively receiving a message),” and that transmission intervals are determined by a code sequence (Ex. 1003, 3:59–4:6; 6:15–33, 6:59–68, Figs. 4, 5); and Neve discloses that “[t]he slave

stations operate in a low power condition except during one of the other time slots when they may receive their own address, or except when they need to transmit data” (Ex. 1004, Abst.), and that the interface circuit of each device is “arranged to energise the transmitter circuit only when transmission is required” (*id.* at 2:42–47); *see also id.* at 5:60–61 (disclosing “low power duty cycle”).

- xi. Neve discloses that the master station provides synchronization signals for all of the other stations (*id.* at 4:10–13, Fig. 2).

b. “*said server . . . transmitter[] being energized in low duty cycle RF bursts*”

As reproduced in Section II.B. *supra*, claim 1 recites, *inter alia*, “said server and peripheral transmitters being energized in low duty cycle RF bursts at intervals determined by a code sequence which is timed in relation to . . . synchronizing information.” The single substantive dispute in this proceeding is whether the combination of Natarajan and Neve teaches or suggests that the recited server transmitter is energized in low duty cycle RF bursts. *See* Pet. 52–54; PO Resp. 15–33; Reply 2–18.

In its Petition, Apple cited Natarajan’s disclosure that “[s]cheduled access multiaccess protocols can be implemented to effectively conserve battery power by suitable control of the state of transmitter and receiver units at the portable units (i.e., by scheduling when they should be turned ON or OFF)” and that “the transmitter (or receiver) consumes power only when it is actively transmitting a message (or actively receiving a message)” as evidence of Natarajan’s disclosure of “low duty cycle RF bursts.”

Pet. 52–53 (citing Ex. 1003, 3:59–4:6; Ex. 1008 ¶ 115). Apple additionally cited Natarajan’s disclosure of a period “for the transfer of all *bursty* data traffic in a contention mode from mobile units to base station (inbound traffic)” and Neve’s disclosure that “[t]he slave stations operate in a low power condition except during one of the other time slots when they may receive their own address, or except when they need to transmit data” and that the interface circuit of each device is “arranged to energise the transmitter circuit only when transmission is required,” in support of its assertion that “Natarajan and Neve each disclose that the transmitters are ‘energized in low duty cycle RF bursts.’” *Id.* at 53 (citing Ex. 1003, 4:36–38; Ex. 1004, Abst., 2:42–47; Ex. 1008 ¶ 115). Apple pointed further to Figures 4 and 5 and corresponding text of Natarajan, as disclosing transmission “intervals determined by a code sequence” as recited by claim 1. *Id.* at 53–54 (citing Ex. 1003, 4:20–23, 5:9–11, 5:20–29, 8:54–62, 6:15–33, 6:59–68, Figs. 4, 5).

In response to Apple’s contentions, DSS argues that Natarajan does not teach or suggest that the server transmitter is energized in low duty cycle RF bursts. PO Resp. 15. According to DSS, “[a]lthough Natarajan teaches a system for reducing power consumption in mobile units, Natarajan is silent regarding the operation of the base unit’s transmitter.” *Id.* at 16. “Natarajan discloses that its objective is to provide energy savings for the mobile units, but does not teach or suggest that there are any energy savings associated with operation of the base unit’s transmitter,” and “[f]or this reason, the base unit’s transmitter could operate continuously during the time slots designated for outbound traffic without undermining the objectives of Natarajan.” *Id.* at 16–17 (citing Ex. 1003, 3:59–61, 10:14–37; Ex. 2016



¶¶ 32, 38). Moreover, according to DSS, “[i]t is well understood in the art that although the base unit and mobile units may be structured similarly, the base and mobile units operate under different schemes,” and accordingly, a person of ordinary skill in the art “would not have concluded that base transmitters operate the same way as the mobile units.” *Id.* at 16 (citing Ex. 1004, 4:10–12; Ex. 2016 ¶ 31). DSS concludes, “Natarajan does not disclose that the server transmitter is energized in a low duty cycle,” and “[t]he logical conclusion is that in the data network system disclosed in Natarajan, the base transmitter is continuously energized during the time periods designated for outbound transmissions.” *Id.* at 18–19.

In further support of its arguments, DSS points to disclosure in Natarajan that serial channels in the base unit’s transmitter “encapsulate data and control information in an HDLC (high-level data link control) packet structure and provide the packet in serial form to the RF transceiver 54,” and contends that “HDLC involves continuous transmissions in which special bit sequences—i.e. idle words—are transmitted when no data transmission is required.” PO Resp. 20–21 (quoting Ex. 1003, 3:34–37) (emphasis omitted). According to DSS, “[t]he HDLC packet structure disclosed in Natarajan is inconsistent with a server transmitter being energized in low duty cycle RF bursts,” and “[i]t is well-known in the art that HDLC is an example of a bit-oriented framing that involves a continuous outbound transmission rather than operation in low duty cycle RF bursts.” *Id.* at 20 (emphasis omitted). In support of that assertion, DSS quotes the following excerpt from the McGraw Hill Encyclopedia of Networking & Telecommunications: “Bit-oriented framing . . . allows the sender to transmit a long string of bits at one time. . . . The beginning and end of a frame is signaled with a special

bit sequence (01111110 for HDLC). If no data is being transmitted, this same sequence is continuously transmitted so the end systems remain synchronized.” Ex. 2010, 549 (quoted at PO Resp. 20–21). According to DSS, “Natarajan’s disclosure of HDLC, which is used for transmitting ‘long strings of data [*sic*] at one time,’ directly contradicts the requirement of claim 1 of the ’290 Patent that server transmitters be energized in RF bursts.” PO Resp. 21. DSS concludes, “a continuous transmission is an antithesis of RF bursts” and “protocols involving transmission of idle words in an absence of active transmissions are inconsistent with server transmitter operating in a low-duty cycle.” *Id.* at 21–22.

DSS further contends that Neve does not cure the alleged deficiencies of Natarajan. PO Resp. 27–33. In particular, according to DSS, Neve does not teach or suggest that server transmitter is energized in low duty cycle RF bursts. *Id.* at 30. DSS acknowledges our finding in the Decision on Institution that Neve does not suggest continuous transmission from the master station and, accordingly, does not teach away from the server transmitter being energized in low duty cycle RF bursts. *Id.* (citing Dec. 19–20). DSS contends, however, that “during the time slots designated for outbound transmissions, ‘[i]f no data is currently required to be transmitted, the master station transmits idle words’” (*id.* (quoting Ex. 1004, 4:48–50)), and argues, “[i]dle words are inconsistent with server transmitter being energized in low duty cycle RF bursts” (*id.*). Again citing Natarajan’s disclosure that data is encapsulated into an HDLC packet structure for the RF transceiver and Neve’s disclosure of idle word transmission, DSS concludes, “[w]hen Natarajan is considered in view of Neve, it becomes even more apparent that these references, either individually or in

combination, do not teach or suggest that server transmitter is energized in low duty cycle RF bursts.” *Id.* at 31–32 (citing Ex. 1003, 3:33–37; Ex. 1004, 4:48–50; Ex. 2016 ¶¶ 34, 35, 45).

In reply, Apple argues that a person of ordinary skill in the art would have understood from Natarajan that, when Natarajan’s base station is not transmitting, its transmitter is powered off. Reply 2–3 (citing Ex. 1003, 6:41–44; Ex. 1008 ¶¶ 27, 115–116; Ex. 1014 (“Hu Decl.”) ¶¶ 44–45; Ex. 2015, 68:5–12, 74:7–19, 75:21–76:3). Apple contends, “DSS acknowledges that Natarajan explicitly discloses that the mobile unit transmitters operate in ‘low duty cycle RF bursts’” (*id.* at 3 (citing PO Resp. 16; Ex. 2016 ¶ 31)), “[s]o even if not expressly taught by Natarajan, it would have been plainly obvious to a [person of ordinary skill in the art] to have the base station operate in an analogous manner” (*id.* (citing Ex. 1014 ¶ 45)). In particular, according to Apple, “[t]he ‘low duty cycle RF bursts’ limitation of claim 1 is not novel,” and “[b]ecause the base and mobile stations have the same physical structure, this would have been no more than using a known technique to improve similar devices in the same way.” *Id.* (citing Ex. 1003, 3:7–8; Ex. 1014 ¶ 45).

Apple further points out that, not only is HDLC consistent with low duty cycle RF bursts, contrary to DSS’s assertions, but the preferred embodiment in the ’290 patent itself utilizes the HDLC protocol. Reply 3–4. According to Apple:

The “basic scheme” of the ’290 patent’s frame structure is “a form of time division multiple access (TDMA).” ([Ex. 1001], 5:45-50.) The ’290 patent states that “[a]s will be ***understood by those skilled in the art***, the TDMA system is greatly facilitated by the establishment of a common frame time base between PEA and PDA.” (*Id.* at 7:63-65 (emphasis added).) This is

accomplished using synchronization beacons (SBs). (*Id.* at 7:65-67.) Before receiving the SBs, a PEA is associated with the PDA using a succession of Attachment Beacons (ABs), which are “composed of RF bursts,” broadcast from the PDA to the PEAs. (*Id.* at 9:8-16, 9:66-10:2.) “This succession of ABs *forms an HDLC channel* using bit-stuffing to delineate the beginning and end of a packet.” (*Id.* at 10:2-4 (emphasis added).)

So, the '290 patent uses HDLC to transmit and receive RF bursts. ([Ex. 1014] ¶¶ 48-49.) Thus, the '290 patent itself shows that DSS's argument is fallacious.

*Id.* at 4.

Apple additionally contends that DSS's evidence and reliance on Mr. Dezmelyk's testimony regarding HDLC should be disregarded for at least the following four reasons:

First, Mr. Dezmelyk admitted in his deposition that he would not say that he is an expert in the HDLC protocol, he is not inventor on any patents related to the HDLC protocol, he has not received any industry awards, related to the HDLC protocol, he has never lectured on the HDLC protocol, and this and the related district court litigation are the only matters he recollects working on that are even related more generally to wireless communication. Reply 5 (citing Ex. 1011, 19:10–20:4, 21:1–22, 26:15–16).

Second, Mr. Dezmelyk did not consider the most logical reference for information on Natarajan's HDLC protocol when forming his opinions. Reply 6. In particular, Apple points out that Natarajan—indeed, in the very next sentence after the one quoted by DSS as evidence of Natarajan's use of the HDLC protocol—states as follows: “For more information on the HDLC packet structure, see, for example, Mischa Schwartz, *Telecommunication Networks: Protocols, Modeling and Analysis*, Addison-Wesley (1988).” *Id.* (quoting Ex. 1004, 3:37–40). Apple contends that “the Schwartz book

([Ex.] 1012) is the most logical resource for a [person of ordinary skill in the art] to consult for information on Natarajan’s HDLC packet structure,” and “Mr. Dezmelyk acknowledged that a [person of ordinary skill] in the art would have access to Schwartz,” and “[y]et Mr. Dezmelyk never looked at Schwartz when considering how Natarajan’s HDLC packet structure operates.” *Id.* (citing Ex. 1011, 71:11–13; Ex. 1014 ¶ 51).

Third, Schwartz not only demonstrates that Natarajan’s HDLC protocol is consistent with low duty cycle communication, but also illustrates that RF transmissions occur in “bursts.” Reply 7–9 (citing Ex. 1012, 135–36 (“When the transmitter reaches its maximum sequence number it is forced to stop transmitting until a frame in the reverse direction is received, acknowledging an outstanding packet.”), Figs. 4–9, 4–13 (showing periods where the transmitter is idle between frames); Ex. 1015 ¶¶ 53, 54).

Fourth, the references that DSS and Mr. Dezmelyk “piece[d] together” in support of the argument that Natarajan does not teach low duty cycle RF bursts “do not support the asserted premise.” Reply 9–15. Apple argues, for example, that DSS’s reliance on the cited excerpt from the Encyclopedia of Networking & Telecommunications is misplaced. *Id.* at 10. According to Apple, whereas “DSS asserts that the cited definition of ‘bit-oriented framing’ shows that HDLC ‘involves continuous outbound transmission,’” DSS neglects to acknowledge the very first sentence of the cited section, which indicates that the excerpt “refers to point-to-point wired communication, not to a *point-to-multipoint wireless* system as taught in Natarajan.” *Id.* (citing Ex. 1014 ¶ 56; Ex. 2010, 549). Relying on Dr. Hu’s testimony, Apple contends “[t]here are fundamental differences and unique

challenges between point-to-point wired systems and point-to-multipoint wireless systems,” and “the features are not simply interchangeable.” *Id.* (citing Ex. 1014 ¶¶ 57–60). For example, Apple asserts, “continuous transmission of so-called ‘idle words’ to maintain synchronization when there is no data to transmit” may be “suitable for an isolated point-to-point wired connection,” but “would be detrimental to a point-to-multipoint wireless connection because it would interfere with the carefully designed scheduling, waste power, decrease the system data rate, and pollute the wireless channel potentially shared by many devices.” *Id.* (citing Ex. 1014 ¶ 59). Apple also points out, for example, that DSS significantly misquotes the cited portion of the Encyclopedia of Networking & Telecommunications (*id.* at 11 (citing PO Resp. 21; Ex. 2010, 549)); that other portions of that same Encyclopedia—not provided by DSS either to the Board or to Mr. Dezmelyk—corroborate Schwartz’s description (*id.* at 11–12 (citing Ex. 1011, 101:4–102:7; Ex. 1012, 135; Ex. 1013, 582, Fig. H-2; Ex. 1014 ¶ 62)); and that other evidence relied upon by Mr. Dezmelyk similarly fails to show that Natarajan teaches continuous transmission and underscores his misunderstanding of HDLC (*id.* at 12–15 (citing, e.g., Ex. 1011, 69:17–71:1, 99:12–20; Ex. 1014 ¶¶ 57–60, 64–68; Ex. Ex. 2013, 2; Ex. 2014 § 2.5.6, 4; Ex. 2016 ¶ 35)).

Lastly, Apple contends that “DSS’s ‘idle words’ argument is a red herring.” Reply 15 (emphasis omitted). According to Apple, Neve was included in combination with Natarajan to show that synchronizing a base station and peripheral units was well-known to those of ordinary skill in the art, not to suggest that Natarajan operates identically to Neve with respect to the latter’s use of idle words. *Id.* at 15–16.

We are persuaded by each of Apple’s arguments presented above, and conclude that it would have been obvious to a person of ordinary skill in the art to energize Natarajan’s server transmitter in low duty cycle RF bursts, as recited in claim 1. We find that Natarajan is expressly concerned with “power conservation due to wireless communication,” and specifically, with “battery efficient operation of wireless link adapters of mobile computers as controlled by multiaccess protocols used in wireless communication.” Ex. 1003, 1:7–13. Although Natarajan describes explicitly only mobile stations as battery-powered devices such as laptop computers, Natarajan also discloses that the base units may be “conventional microcomputer[s]” (*id.* at 2:40–41) and that the mobile units are similarly provided with the same components—e.g., RF transceiver adapter 36, including “a spread spectrum transceiver of convention design” and antenna 38, in the base station; and transceiver adapter 44, including “a spread spectrum transceiver of similar design” and antenna 42, in each mobile unit (*id.* at 2:51–3:2). We are persuaded that a person of ordinary skill in the art would have been motivated by Natarajan to apply the same power-conserving techniques to base units as it is disclosed with respect to mobile units, as well as that it would have been within the skill of the ordinarily skilled artisan to do so. There is no persuasive evidence of record that it would have been “uniquely challenging or difficult for one of ordinary skill in the art” to do so. *See Leapfrog Enters., Inc. v. Fisher-Price, Inc.*, 485 F.3d 1157, 1162 (Fed. Cir. 2007) (citing *KSR*, 550 U.S. at 418). Indeed, as the Court explained in *KSR*, the skilled artisan is “a person of ordinary creativity, not an automaton.” 550 U.S. at 420–21.

We also find that Natarajan's disclosure of the HDLC protocol is consistent with Natarajan's base units being energized in low duty cycle RF bursts, as that term is properly construed. *See supra* Section II.C. In that regard, the Schwartz reference (Ex. 1012), which was cited by Natarajan (*see* Ex. 1003, 3:37–40), is significantly more probative of how a person of ordinary skill in the art would have understood Natarajan's reference to HDLC than the Encyclopedia of Networking & Telecommunications excerpt (Ex. 2010) cited by DSS, which, by its own terms, describes HDLC within the context of a point-to-point network. Mr. Dezmelyk's failure to consider Schwartz or other portions of the Encyclopedia of Networking & Telecommunications beyond those specifically provided to him by DSS (*see* Ex. 1011, 71:11–73:13, 101:4–102:7, 104:9–11), as well as his admitted lack of expertise regarding the HDLC protocol (*see id.* at 19:13–20:22, 26:15–16), call into question the credibility of his opinion on HDLC. Accordingly, we do not find persuasive the testimony of Mr. Dezmelyk on that subject. Additionally, the employment of an HDLC channel in the preferred embodiment of the '290 patent (Ex. 1001, 10:2–4) contradicts DSS's assertion that "[t]he HDLC packet structure is inconsistent with a server transmitter being energized in low duty cycle RF bursts" (PO Resp. 20–22).

Finally, because we are not persuaded by DSS's arguments that Natarajan is deficient, we are not persuaded by DSS's arguments that Neve does not cure the alleged deficiencies of Natarajan or that the combination of Neve and Natarajan does not teach or suggest that the server transmitter is energized in low duty cycle RF bursts. PO Resp. 27–33. In this proceeding, Apple relies on Neve only as evidence that it was well-known and would



have been obvious to those of ordinary skill in the art for a base station transmitter to send “synchronizing information” to mobile units, as recited in claim 1, which feature Apple contends is suggested but not explicitly described by Natarajan. Pet. 55–56; Reply 15–16. In contrast, Apple relies on Natarajan alone—not Neve—for the suggestion of “said server . . . transmitter[] being energized in low duty cycle RF bursts.” See Pet. 52–54; Reply 1–15. Accordingly, DSS’s contentions that Neve does not separately teach or suggest “said server . . . transmitter[] being energized in low duty cycle RF bursts” are unavailing. See *In re Keller*, 642 F.2d 413, 426 (CCPA 1981) (“[O]ne cannot show non-obviousness by attacking references individually where, as here, the rejections are based on combinations of references.”). Moreover, “[t]he test for obviousness is not whether the features of a secondary reference may be bodily incorporated into the structure of the primary reference; . . . [r]ather, the test is what the combined teachings of the references would have suggested to those of ordinary skill in the art.” *Id.* at 425 (citations omitted). We are not persuaded that combination of Neve’s teachings on synchronizing information with Natarajan’s disclosure would necessitate incorporation of Neve’s use of “idle words,” let alone that it would require “continuous transmission” or be “inconsistent with server transmitter being energized in low duty cycle RF bursts.” PO Resp. 30–33. As we explained in our Decision on Institution, we do not find Neve to suggest continuous transmission from its master station, but instead only transmission of idle words in the event that that there is no data required to be transmitted in the time slots specifically allocated for transmission by the server. Dec. 19–20.

#### 4. *Conclusion of Obviousness*

As explained above, we find, based on Apple's evidence, that the combination of Natarajan and Neve teaches each limitation of claim 1. We also find, based on Apple's evidence, that a skilled artisan would have had reasons, with rational underpinning, to combine these teachings to arrive at the invention of claim 1. We have considered DSS's arguments to the contrary and find them unpersuasive. The parties do not introduce or rely on objective indicia of nonobviousness. After weighing the evidence, we conclude that Apple has shown by a preponderance of the evidence that claim 1 would have been obvious over Natarajan and Neve.

Claims 2–4 depend from claim 1. Apple introduced evidence and argument as to the obviousness of each of these claims. Pet. 56–59. We have considered the evidence in the Petition and are persuaded, for the reasons presented by Apple, that Apple has shown by a preponderance of the evidence that claims 2–4 would have been obvious over Natarajan and Neve. DSS does not present separate arguments for claims 2–4. Rather, DSS argues that these claims are patentable for the reasons given for claim 1. PO Resp. 36. As explained above, these reasons are not persuasive. By not raising them in its Patent Owner Response, DSS has waived any additional argument regarding claims 2–4. Scheduling Order, Paper 10, 3 (“The patent owner is cautioned that any arguments for patentability not raised in the response will be deemed waived.”); *see also* 37 C.F.R. § 42.23(a) (“Oppositions and replies . . . must include a statement identifying material facts in dispute. Any material fact not specifically denied may be considered admitted.”).

### III. MOTION TO EXCLUDE

Apple filed a Motion to Exclude DSS's Exhibits 2003–2008, 2011–2014, and 2017. Paper 27 (“Mot. Excl.”). DSS filed an Opposition to Apple's Motion to Exclude (Paper 32, “Opp. Mot. Excl.”), and Apple filed a Reply to DSS's Opposition (Paper 33, “Reply Mot. Excl.”).

In *inter partes* review proceedings, documents are admitted into evidence subject to an opposing party asserting objections to the evidence and moving to exclude the evidence. 37 C.F.R. § 42.64. As movant, Apple has the burden of showing that an objected-to exhibit is not admissible. 37 C.F.R. § 42.20(c).

For the reasons discussed below, we deny Apple's Motion to Exclude as to all objected-to exhibits.

#### A. *Relevance*

Apple seeks to exclude Exhibits 2003–2008, 2012–2014, and 2017 under Fed. R. Evid. 401 as irrelevant. Mot. Excl. 1–10. First, Apple argues, Exhibits 2003–2008, 2012, and 2013 all bear copyright or filing dates well after the priority date of the '290 patent and, accordingly, are not remotely or sufficiently contemporaneous with the '290 patent to be relevant for the purposes for which they are proffered. *Id.* at 2, 4, 6, 7. Similarly, according to Apple, “Exhibit 2017 is undated, so its relevance also cannot be established because DSS cannot show that Exhibit 2014 is sufficiently contemporaneous with the '290 patent to be relevant.” *Id.* at 10. Second, Apple argues, DSS does not cite Exhibits 2003 and 2012–2014 in its Patent Owner Response or identify with any particularity how those exhibits are relevant to this proceeding. *Id.* at 3, 6–9.

DSS responds that Petitioner’s allegations are unavailing. Opp. Mot. Excl. 4. DSS points out Fed. R. Evid. 401 provides that evidence is relevant if “it has any tendency to make a fact more or less probable than it would be without the evidence” and “the fact is of consequence in determining the action,” and that “[b]oth the Federal Circuit and the Board have recognized that there is a ‘low threshold for relevancy.’” *Id.* (citing *OddzOn Prods., Inc. v. Just Toys, Inc.*, 122 F.3d 1396, 1407 (Fed. Cir. 1997); *Laird Techs., Inc. v. GrafTech Int’l Holdings, Inc.*, Case IPR2014-00025, slip op. at 44 (PTAB Mar. 25, 2015) (Paper 45)). DSS also contends that Mr. Dezmelyk—who DSS proffers as an expert witness in this matter—relies on each of the objected-to exhibits in his declaration, and therefore, this evidence is relevant for the assessment of his credibility and for establishing the context for his testimony. *Id.* at 6.

We agree with DSS on this issue. In this case, we determine that Apple’s arguments concerning the relevance of Exhibits 2003–2008, 2012–2013, and 2017 in view of their late or uncertain dates concern the weight that we should accord to those exhibits, rather than their admissibility. As explained in *Laird Technologies*, “[a] motion to exclude . . . is not an appropriate mechanism for challenging the sufficiency of evidence or the proper weight that should be afforded an argument.” Case IPR2014-00025, slip op. at 42 (Paper 45). Moreover, “[o]ur general approach for considering challenges to the admissibility of evidence was outlined in *Corning Inc. v. DSM IP Assets B.V.*, Case IPR2013-00053, slip op. at 19 (PTAB May 1, 2014),” which stated that, “similar to a district court in a bench trial, the Board, sitting as a non-jury tribunal with administrative expertise, is well-positioned to determine and assign appropriate weight to evidence

presented.” *Id.* (citing *Donnelly Garment Co. v. NLRB*, 123 F.2d 215, 224 (8th Cir. 1941) (“One who is capable of ruling accurately upon the admissibility of evidence is equally capable of sifting it accurately after it has been received . . . .”). Further, although DSS does not appear to cite Exhibits 2003 and 2012–2014 in its Patent Owner Response, we agree with DSS that those exhibits are relevant for the assessment of Mr. Dezmelyk’s credibility to the extent that he has cited them in support of his opinions.

*B. Hearsay*

Apple additionally seeks to exclude each of Exhibits 2003–2008, 2011–2014, and 2017 as inadmissible hearsay under Fed. R. Evid. 801 not subject to any exception. Mot. Excl. 1–2, 4–8, 10.

DSS responds that each of Exhibits 2003–2008, 2011–2014, and 2017 is admissible because they are offered for what they describe to a person of ordinary skill in the art, rather than for the truth of the matters asserted in them, and “[t]he law is well established that the Board will not exclude evidence that is proffered to show what a [person of ordinary skill in the art] would have known about the relevant field of art.” Opp. Mot. Excl. 2 (citing *Liberty Mut. Ins. Co. v. Progressive Cas. Ins.*, Case CBM2012-00010 (PTAB Feb. 24, 2014) (Paper 59)).

In its Reply to DSS’s Opposition, Apple argues that DSS and Mr. Dezmelyk simply provide quotations from the objected-to exhibits, rather than offering them “for what they describe to a person of ordinary skill in the art,” and, thus, offer them “exactly for the impermissible purpose of proving the truth of the matter asserted therein.” Reply Mot. Excl. 1. Moreover, according to Apple, because Exhibits 2003–2008, 2012–2014,

and 2017 all post-date the '290 patent or are undated, those exhibits “therefore cannot ‘show what one with ordinary skill in the art *would have known* about technical features and developments in the pertinent art’” at the time the invention was made. *Id.* (quoting *Liberty Mut.*, slip op. at 37 (emphasis added by Apple)) (citing 35 U.S.C. § 103(a)).

We agree with DSS on this issue, as well. Although DSS has quoted certain phrases from the references, we understand DSS to have offered each of the objected-to exhibits for the effect that they would have had on the understanding of a person of ordinary skill in the art, rather than for the truth of the matters asserted. The portion of Exhibit 2004 cited by DSS, for example, states:

[FIG. 2(a) is a flow chart of the steps performed by the adaptive duty cycle management system shown in FIG. 1] whereby a relatively high duty cycle, e.g. 25%, is applied and FIG. 2(b) is a flow chart showing the special case steps performed by the adaptive duty cycle management system whereby a relatively low duty cycle, e.g. 2%, is applied . . . .

Ex. 2004, 4:13–16 (cited at PO Resp. 12). We understand DSS to have cited this text only for the alleged effect that the statements “high duty cycle, e.g. 25%” and “low duty cycle, e.g. 2%” would have on the ordinarily skilled reader, in support of DSS’s conclusion that a person of ordinary skill in the art “would have understood that a server transmitter is energized in a low duty cycle when the server transmitter is energized for less than ten percent (10%) of the total duration designated for outbound transmissions.” PO Resp. 11. Whether or not it is “true” that Figures 2(a) and 2(b) of Exhibit 2004 are flow charts of systems whereby relatively high (e.g., 25%) and low (e.g., 2%) duty cycles are applied, respectively, has no discernable bearing on DSS’s conclusion. We find that a similar analysis applies with

respect to each of the other objected-to exhibits, with respect to which DSS's conclusions do not turn on whether the described systems truly operated according to the specified duty cycles (Exs. 2003, 2005–2008) or truly transmitted data in the manner specified (Exs. 2011–2014, 2017).

*C. Conclusion*

For the foregoing reasons, Apple's Motion to Exclude Exhibits 2003–2008, 2011–2014, and 2017 is denied.

IV. MOTION FOR OBSERVATION

DSS filed a Motion for Observation regarding Dr. Hu's cross-examination. Paper 29 ("Obs."). Apple, in turn, filed a Response. Paper 31 ("Obs. Resp."). To the extent DSS's Motion for Observation pertains to testimony purportedly impacting Dr. Hu's credibility, we have considered DSS's observations and Apple's responses in rendering this Final Written Decision, and accorded Dr. Hu's testimony appropriate weight where necessary. *See* Obs. 2–6; Obs. Resp. 1–5.

V. CONCLUSION

Apple has demonstrated by a preponderance of the evidence that claims 1–4 of the '290 patent are unpatentable under 35 U.S.C. § 103(a) over Natarajan and Neve.

VI. ORDER

For the reasons given, it is

ORDERED, based on a preponderance of the evidence, that claims 1–4 of U.S. Patent No. 6,128,290 are held unpatentable;

IPR2015-00369  
Patent 6,128,290

FURTHER ORDERED that Apple's Motion to Exclude is DENIED;  
and

FURTHER ORDERED, because this is a final written decision, that the parties to this proceeding seeking judicial review of our Decision must comply with the notice and service requirements of 37 C.F.R. § 90.2.



IPR2015-00369  
Patent 6,128,290

For PETITIONER:

David K.S. Cornwell  
Jason A. Fitzsimmons  
Mark W. Rygiel  
Robert Greene Sterne  
STERNE, KESSLER, GOLDSTEIN & FOX P.L.L.C.  
[davidc-PTAB@skgf.com](mailto:davidc-PTAB@skgf.com)  
[jfitzsimmons-PTAB@skgf.com](mailto:jfitzsimmons-PTAB@skgf.com)  
[mrygiel-PTAB@skgf.com](mailto:mrygiel-PTAB@skgf.com)  
[rsterne-PTAB@skgf.com](mailto:rsterne-PTAB@skgf.com)

For PATENT OWNER:

Andriy Lytvyn  
Anton J. Hopen  
Nicholas Pfeifer  
SMITH HOPEN PA  
[andriy.lytvyn@smithhopen.com](mailto:andriy.lytvyn@smithhopen.com)  
[anton.hopen@smithhopen.com](mailto:anton.hopen@smithhopen.com)  
[nicholas.pfeifer@smithhopen.com](mailto:nicholas.pfeifer@smithhopen.com)