

UNITED STATES PATENT AND TRADEMARK OFFICE

BEFORE THE PATENT TRIAL AND APPEAL BOARD

SAMSUNG ELECTRONICS CO., LTD.,
Petitioner,

v.

CYWEE GROUP LTD.,
Patent Owner.

Case IPR2019-00535
Patent 8,441,438 B2

Before PATRICK M. BOUCHER, KAMRAN JIVANI, and
CHRISTOPHER L. OGDEN, *Administrative Patent Judges*.

OGDEN, *Administrative Patent Judge*.

DECISION

Petition for *Inter Partes* Review and Motion for Joinder
35 U.S.C. §§ 314(a), 315(c)

I. INTRODUCTION

Samsung Electronics Co., Ltd. (“Petitioner”) filed (1) a Petition for *inter partes* review (Paper 1, “Pet.”) of claims 1 and 3–5 of U.S. Patent No. 8,441,438 B2 (Ex. 1001, “the ’438 patent”); and (2) a Motion for Joinder (Paper 3, “Mot.”) with IPR2018-01258 (“the related IPR”), for which we instituted an *inter partes* review on December 11, 2018. Cywee Group Ltd. (“Patent Owner”), filed a Preliminary Response (Paper 9, “Prelim. Resp.”) to the Petition, as well as an Opposition (Paper 6, “Opp.”) to Petitioner’s Motion for Joinder. Petitioner also filed a Reply (Paper 7, “Reply”) to Patent Owner’s Opposition.

For the reasons discussed below, we grant the Motion for Joinder, joining Petitioner as a party to the related IPR, and terminate this proceeding.

II. BACKGROUND

A. REAL PARTIES IN INTEREST

Petitioner identifies itself and Samsung Electronics America, Inc. as the real parties in interest. Pet. 1. Patent Owner identifies itself as the real party in interest. Paper 5, 2.

B. RELATED PROCEEDINGS

The parties identify the following as matters relating to the ’438 patent: *Cywee Group Ltd. v. Google, Inc.*, No. 1:18-cv-00571 (D. Del.); *Cywee Group Ltd. v. ZTE Corporation et al.*, No. 3:17-cv-02130 (S.D. Cal.); *Cywee Group Ltd. v. HTC Corporation et al.*, No. 2:17-cv-00932 (W.D. Wash.); *Cywee Group Ltd. v. Motorola Mobility LLC*, No. 1:17-cv-00780 (D.

IPR2019-00535
Patent 8,441,438 B2

Del.); *Cywee Group Ltd. v. Huawei Technologies Co., Inc. et al.*, No. 2:17-cv-00495 (E.D. Tex.); *Cywee Group Ltd. v. LG Electronics, Inc. et al.*, Case No. 3:17-cv-01102, (S.D. Cal.); *Cywee Group Ltd. v. Samsung Electronics Co. Ltd. et al.*, No. 2:17-cv-00140 (E.D. Tex.); and *Cywee Group Ltd. v. Apple Inc.*, No. 4:14-cv-01853 (N.D. Cal.). Pet. 1–2; Paper 5, 2–3.

ZTE (USA), Inc. v. CyWee Group Ltd., Case IPR2019-00143 (PTAB) is a separate proceeding involving the same patent as this Petition, but relying on different prior art. Pet. 2; Paper 5, 3. In addition, other parties have filed petitions and moved to join the related IPR in the following matters: IPR2019-00526 (*ZTE (USA), Inc.*), IPR2019-00559 (*LG Electronics Inc.*), and IPR2019-00562 (*Huawei Device USA, Inc. et al.*). See Paper 5, 3.

Related U.S. Patent No. 8,552,978 B2 (“the ’978 patent”) is the subject of IPR2018-01257. Petitioner has filed a petition challenging claims of the ’978 patent, as well as a motion to join IPR2018-01257 in IPR2019-00534. In addition, other parties have filed petitions and moved to join IPR2018-01257 in the following matters: IPR2019-00525 (*ZTE (USA), Inc.*), IPR2019-00560 (*LG Electronics Inc.*), and IPR2019-00563 (*Huawei Device USA, Inc. et al.*).

C. THE ’438 PATENT (EX. 1001)

The ’438 patent “relates to a three-dimensional (3D) pointing device.” Ex. 1001, 1:17–18. This device includes “a six-axis motion sensor module including a rotation sensor and an accelerometer.” *Id.*, Abstract. Figure 1 of the ’438 patent, reproduced below, provides background for the invention:

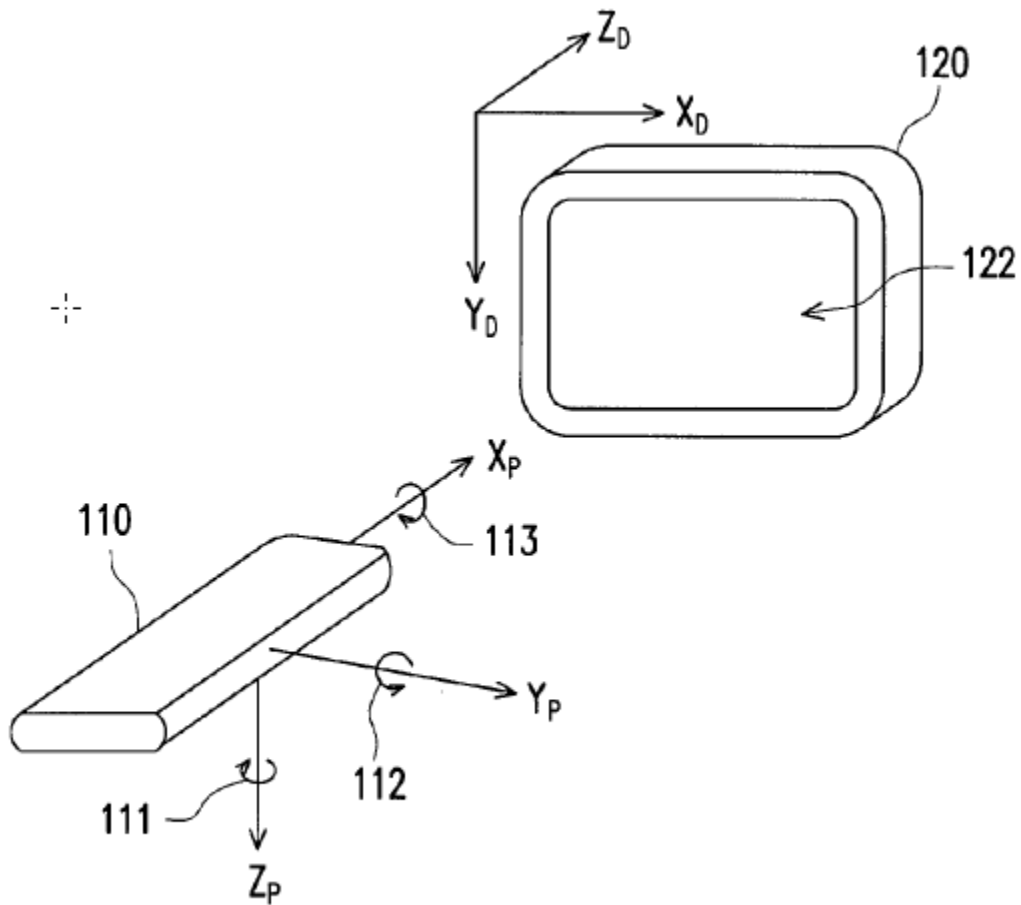

FIG. 1 (RELATED ART)

Figure 1 is a schematic diagram depicting handheld 3D pointing device 110, which a user may point at screen 122 of display device 120. Ex. 1001, 1:28–30. The figure also depicts a reference frame, called the “spatial pointer reference frame,” associated with pointing device 110, which is defined by coordinate axes X_P , Y_P , and Z_P (113, 112, and 111, respectively). *Id.* at 1:38–41.

Figure 4 of the patent, reproduced below, is a schematic diagram of the pointing device’s hardware components:

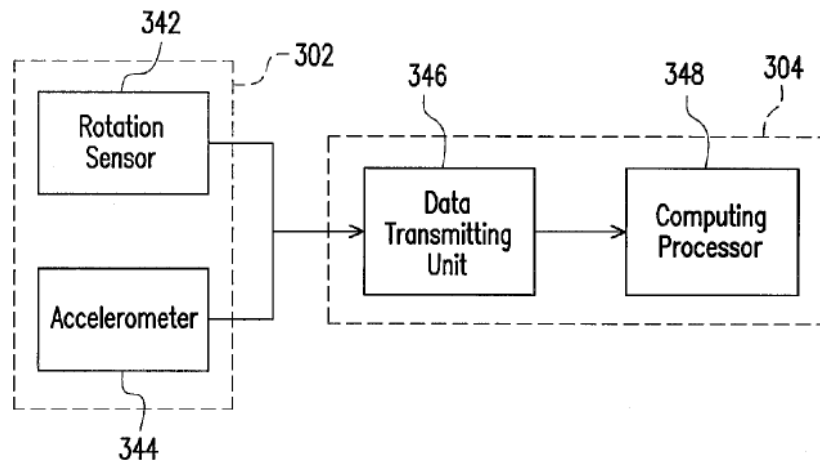

FIG. 4

A box in Figure 4 depicts six-axis motion sensor module 302, which includes rotation sensor 342 and accelerometer 344. *Id.* at 7:59–61. Another box depicts processing and transmitting module 304, which includes data transmitting unit 346 and computing processor 348. *Id.* at 7:61–63.

Figure 4 also includes arrows from rotation sensor 342 and accelerometer 344 to data transmitting unit 346, depicting the flow of first and second signal sets, respectively, and an arrow from data transmitting unit 346 to computer processor 348. *See id.* at 7:64–8:26. The first signal set, from rotation sensor 342, includes “angular velocities ω_x , ω_y , and ω_z associated with the movements and rotations of the 3D pointing device” about the coordinate axes of the reference frame. *Id.* at 7:65–8:2. The second signal set, from accelerometer 344, includes “axial accelerations A_x , A_y , A_z associated with the movements and rotations of the 3D pointing device . . . along each of the three orthogonal coordinate axes X_P Y_P Z_P of the spatial pointer reference frame.” *Id.* at 8:4–8.

Using the first and second signal sets, the pointing device compensates for accumulated errors, over time, in the device’s estimation of

its spatial orientation. *See id.*, 1:17–26, 4:6–30. The '438 patent depicts one embodiment of this method as a flowchart in Figure 7, reproduced below:

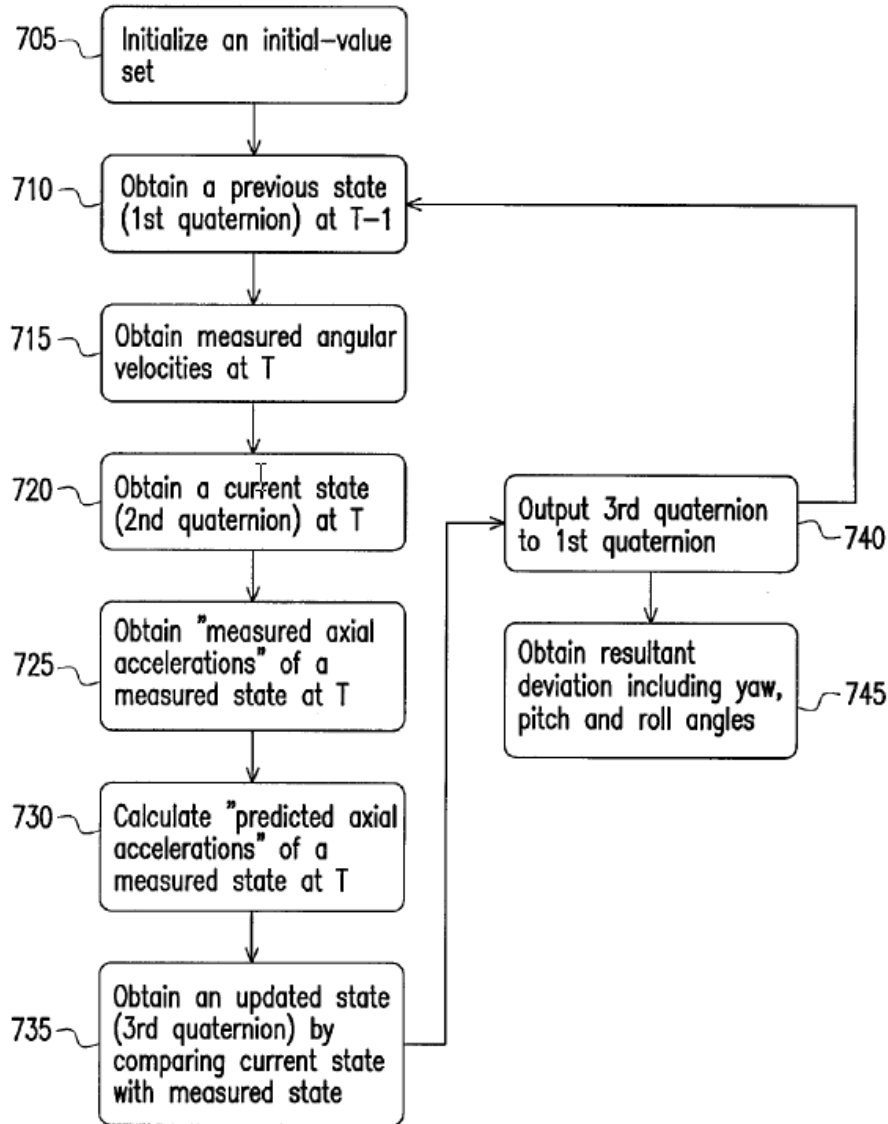

FIG. 7

The method in this flowchart starts with either initializing a new state or “obtaining a previous state of the six-axis motion sensor module (. . . steps 705, 710).” *Id.* at 10:66–11:1. This state is in the form of “a first

quaternion^[1] associated with previous angular velocities ω_x , ω_y , ω_z gained from the motion sensor signals of the six-axis motion sensor module at a previous time $T-1$.” *Id.* at 11:2–4.

The method proceeds by “obtaining measured angular velocities ω_x , ω_y , ω_z gained from the motion sensor signals of the six-axis motion sensor module at a current time T (. . . steps 715, 720),” to form a second quaternion representing the “current state.” *Id.* at 11:6–8, 12:32–60. The method then obtains a “measured state” using sets of axial accelerations: “measured axial accelerations A_x , A_y , A_z ” from the accelerometer (step 725), and “predicted axial accelerations A_x' , A_y' , A_z' ,” which are calculated based on the measured angular velocities (step 730). *Id.* at 11:6–12, 12:61–13:24. Using the “measured state,” the method next obtains a third quaternion, representing an “updated state,” by comparing the current state with the measured state (step 735). *Id.* at 11:15–18, 13:25–14:34.

“[T]o provide a continuous loop,” the method then outputs and substitutes the updated state (step 740) into the first quaternion in the previous state (step 710). *Id.* at 11:22–29. Ultimately, the method generates a resultant deviation, in terms of yaw, pitch, and roll angles, with respect to the axes of the spatial pointer reference frame. *Id.* at 14:47–15:7. According to the '438 patent, one may use these deviation angles to map locations from 3D space to corresponding locations to which the device is pointing on a 2D display device. *See id.* at 15:39–17:40, Figs. 8, 9.

¹ Petitioner’s declarant Majid Sarrafzadeh explains that a quaternion is a four-valued generalization of complex numbers, which has properties allowing it to describe rotations efficiently. Ex. 1002 ¶¶ 29–30.

D. CHALLENGED CLAIMS AND ASSERTED GROUNDS OF
UNPATENTABILITY

Petitioner challenges the patentability of claims 1 and 3–5 of the '438 patent under 35 U.S.C. § 103(a) (2006).² Pet. 3. Independent claim 1 of the '438 patent is as follows:

1. *A three-dimensional (3D) pointing device* subject to movements and rotations in dynamic environments, comprising:
 - a housing associated with said movements and rotations of the 3D pointing device in a *spatial pointer reference frame*;
 - a printed circuit board (PCB) enclosed by the housing;
 - a six-axis motion sensor module attached to the PCB*, comprising a rotation sensor for detecting and generating a first signal set comprising angular velocities ω_x , ω_y , ω_z associated with said movements and rotations of the 3D pointing device in the spatial pointer reference frame,
 - an accelerometer for detecting and generating a second signal set comprising axial accelerations A_x , A_y , A_z associated with said movements and rotations of the 3D pointing device in the spatial pointer reference frame; and
 - a processing and transmitting module, comprising a data transmitting unit electrically connected to the six-axis motion sensor module for transmitting said first and second signal sets thereof and a computing processor for receiving and calculating said first and second signal sets from the data transmitting unit, communicating with the six-axis motion sensor module to calculate a resulting deviation comprising resultant angles in said spatial pointer reference frame by *utilizing a comparison to compare the first signal set with the second signal set* whereby said resultant angles in the spatial pointer reference frame of the resulting deviation of the six-axis motion sensor module of the 3D

² Because the '438 patent was filed before March 16, 2013, the applicable version of 35 U.S.C. § 103 is the one that existed prior to the Leahy–Smith America Invents Act. *See* Pub. L. No. 112-29, sec. 3(n)(1), 125 Stat. 284, 293 (2011).

pointing device are obtained under said dynamic environments, wherein the comparison utilized by the processing and transmitting module further comprises an update program to obtain an updated state based on a previous state associated with said first signal set and a measured state associated with said second signal set; wherein the measured state includes a measurement of said second signal set and a predicted measurement obtained based on the first signal set without using any derivatives of the first signal set.

Ex. 1001 at 18:54–19:26 (emphases added to indicate key terms and disputed claim limitations). The remaining challenged claims 3–5 depend from claim 1. *See id.* at 19:32–48.

The table below is a summary of the ground in the Petition:

| References | Basis | Challenged Claims |
|--|----------|-------------------|
| Zhang ³ and Bachmann ⁴ | § 103(a) | 1 and 3–5 |

Petitioner supports its Petition with the Declaration of Prof. Majid Sarrafzadeh, June 13, 2018. Ex. 1002. Patent Owner also submits the Declaration of Joseph LaViola, Ph.D., Apr. 15, 2019. Ex. 2004.

III. ANALYSIS

In the related IPR, we instituted an *inter partes* review on the ground set forth above. *Google LLC v. Cywee Group Ltd.*, Case IPR2018-01258, slip op. at 9, 36 (PTAB Dec. 11, 2018) (Paper 7). We agree with Petitioner that the Petition is “substantively identical” to the petition in the related IPR.

³ Zhang et al., US 2004/0095317 A1 (published May 20, 2004) (“Zhang”). Ex. 1005.

⁴ Bachmann et al., US 7,089,148 B1 (issued Aug. 8, 2006) (“Bachmann”). Ex. 1004.

See Mot. 1; Ex. 1050 (redlined comparison of the two petitions). Patent Owner’s Preliminary Response differs in certain respects from the preliminary response that Patent Owner filed in the related IPR. Patent Owner also relies on the testimony of a different witness. *See* Ex. 2004. In light of Patent Owner’s arguments and evidence specific to this proceeding, we determine for the reasons below that the Petition “warrants the institution of an inter partes review.” 35 U.S.C. § 315(c).

A. LEVEL OF ORDINARY SKILL IN THE ART

As part of evaluating whether or not the challenged claims are unpatentable for obviousness, we consider what the level of ordinary skill in the pertinent art was at the time of the invention. *Graham v. John Deere Co.*, 383 U.S. 1, 17 (1966). The level of ordinary skill is also relevant to construing the patent claims. *See Phillips v. AWH Corp.*, 415 F.3d 1303, 1313 (Fed. Cir. 2005) (en banc). The “person of ordinary skill in the art” is a hypothetical construct, from whose vantage point we assess obviousness and claim interpretation. *Id.*; *In re Rouffet*, 149 F.3d 1350, 1357 (Fed. Cir. 1998); *Ferguson Beauregard/Logic Controls, Div. of Dover Res., Inc. v. Mega systems, LLC*, 350 F.3d 1327, 1338 (Fed. Cir. 2003).

Petitioner’s declarant Prof. Sarrafzadeh opines that a person of ordinary skill in the art “had an undergraduate degree in computer science, electrical engineering, mechanical engineering, or other related technical field, and knowledge of sensor systems.” Ex. 1002 ¶ 23; Pet. 35. This statement is consistent with our articulation of the level of skill in the related IPR. *See Google*, slip op. at 19. However, for reasons we addressed in that opinion, we determined, for purposes of that decision, that a skilled artisan

would have also been familiar with quaternion mathematics. *Id.* at 18–19. We based this preliminary determination, in part, on Prof. Sarrafzadeh’s testimony. *Id.* at 18 n.11. (citing Ex. 1002 ¶¶ 29–31).⁵

Patent Owner’s declarant, Dr. LaViola, opines that an ordinarily-skilled artisan would have had

at least a Bachelor’s Degree in Computer Science, Electrical Engineering, Mechanical Engineering, or Physics, or equivalent work experience, along with knowledge of sensors (such as accelerometers, gyroscopes, and magnetometers), and mobile computing technologies. In addition, a [person having ordinary skill in the art] would be familiar with Kalman filters and EKFs, and with equations typically used with such filters.

Ex. 2004 ¶ 27. Dr. LaViola’s proposed level of ordinary skill is similar to that we adopted in the related IPR, except that Dr. LaViola does not address quaternions, and adds familiarity with mobile computing technologies, filters, and equations relating to filters.

In the preliminary phase of an *inter partes* review, we view disputes created by testimonial evidence in the light most favorable to the petitioner. *See* 37 C.F.R. 42.108(c). Thus, we maintain the articulation of the level of ordinary skill that we adopted in the related IPR, based on Prof. Sarrafzadah’s testimony. However, our conclusion would be the same even under Dr. LaViola’s articulation of the standard. Even if an ordinarily skilled artisan lacked familiarity with quaternions, the Bachmann reference provides guidance on their use, and any additional familiarity with mobile devices

⁵ The district court in a parallel case in the Eastern District of Texas made a similar finding that a person of ordinary skill in the art would have been familiar with quaternions. *See* Ex. 2006, 10 (“The concepts of a quaternion, angular velocity, and axial accelerations are familiar to persons of skill in the art and would not be confusing . . .”).

and filters would, if anything, strengthen the reason for combining the references that Petitioner proposes.

So for purposes of this Decision, we consider a person of ordinary skill in the art to have an undergraduate degree in computer science, electrical engineering, mechanical engineering, or other related technical field, and knowledge of sensor systems and quaternion mathematics.

B. CLAIM CONSTRUCTION

Between the time of the petition in the related IPR and the filing of the instant Petition, the Board changed the claim-construction standard it uses in trial proceedings. *See* Changes to the Claim Construction Standard for Interpreting Claims in Trial Proceedings Before the Patent Trial and Appeal Board, 83 Fed. Reg. 51,340, 51,340 (Oct. 11, 2018) (“This rule is effective on November 13, 2018 and applies to all IPR, PGR and CBM petitions filed on or after the effective date.”). In the related IPR, we construed the claims using the broadest reasonable interpretation in light of the patent specification. *Google*, slip op. at 12 (citing 37 C.F.R. § 42.100(b) (2017)). Under the rule now in effect for new petitions, the Board uses

the same claim construction standard that would be used to construe the claim in a civil action under 35 U.S.C. 282(b), including construing the claim in accordance with the ordinary and customary meaning of such claim as understood by one of ordinary skill in the art and the prosecution history pertaining to the patent.

83 Fed. Reg. at 51358 (to be codified at 37 C.F.R. § 42.100(b)); *see Phillips v. AWH Corp.*, 415 F.3d 1303, 1312–13 (Fed. Cir. 2005) (en banc).

Petitioner contends that we nevertheless “should apply the [broadest reasonable interpretation] standard to the instant petition because Samsung is

simply seeking joinder as a co-petitioner to the Google proceeding.” Pet. 12 n.2. Patent Owner conversely contends that, because the Petition was filed after November 13, 2018, it “should be subject to claim construction under the *Phillips* standard.” Opp. 8. For the reasons explained below, we need not resolve which claim-construction standard to apply under the specific circumstances presented to us, because we would reach the same ultimate decision in either case.

Petitioner asks us to construe the terms *comparison* and *spatial pointer reference frame* in claim 1. *See* Pet. 13–16. Patent Owner asks us to construe the term three-dimensional (3D) pointing device. *See* Prelim. Resp. 25–29. We address each of these terms below.

1. “*Comparison*”

Claim 1 recites “utilizing a *comparison* to compare the first signal set with the second signal set whereby said resultant angles . . . are obtained under said dynamic environments.” Ex. 1001, 19:12–17 (emphasis added). Also, “the *comparison* utilized by the processing and transmitting module further comprises an update program to obtain an updated state based on a previous state associated with said first signal set and a measured state associated with said second signal set.” *Id.* at 19:17–23 (emphasis added).

To interpret *comparison*, Petitioner points to the following passage in the ’438 patent:

The term of “comparison” of the present invention may generally refer to the calculating and obtaining of the actual deviation angles of the 3D pointing device 110 with respect to the first reference frame or spatial pointing frame $X_P Y_P Z_P$ utilizing signals generated by motion sensors while reducing or eliminating noises associated with said motion sensors.

Ex. 1001, 2:26–32; *see* Pet. 13. In light of this, Petitioner argues that in the context of the ’438 patent, *comparison* means “performing calculations based on sensor signals to obtain the orientation of the device with respect to the spatial pointing frame in a way that reduces the effect of sensor noise.” Pet. 14 (citing Ex. 1002 ¶¶ 37–39).

Because we agreed with the petitioner in the related IPR that the ’438 patent expressly defines the term *comparison*, we construed the term according to its definition in the patent. *Google*, slip op. at 14 (citing Ex. 1001 at 2:28–32); *see also Vitronics Corp. v. Conceptronic, Inc.*, 90 F.3d 1576, 1582 (Fed. Cir. 1996) (“The specification acts as a dictionary when it expressly defines terms used in the claims or when it defines terms by implication.”). In this proceeding, Patent Owner agrees that this construction is “consistent with how the term would be understood by a [person of ordinary skill in the art].” Prelim. Resp. 29–30.

Because our construction is based on an explicit definition in the patent, it would be the same under either the broadest reasonable interpretation or the district court standard.⁶ Accordingly, we construe the term *comparison* as “the calculating and obtaining of the actual deviation angles of the 3D pointing device . . . with respect to the first reference frame or spatial pointing frame $X_P Y_P Z_P$ utilizing signals generated by motion sensors while reducing or eliminating noises associated with said motion sensors.” Ex. 1001, 2:28–32.

⁶ *See* Ex. 2006, 10 (E.D. Tex. claim construction order, holding that “[t]he term ‘comparison’ is specifically defined in the patents.” (citing Ex. 1001, 2:26–32)).

2. “*spatial pointer reference frame*”

Claims 1 and 4 recite “a spatial pointer reference frame.” Ex. 1001, 18:18–59, 65–66, 19:2–3, 11–12, 14–15, 36–37, 41–42. Petitioner proposes that we construe the phrase as “a reference frame associated with the 3D pointing device, which always has its origin at the same point in the device and in which the axes are always fixed with respect to the device.” Pet. 14 (citing Ex. 1002 ¶¶ 40–49). Petitioner asserts that Patent Owner “agreed to this construction during a co-pending litigation.” *Id.* at 14 (citing Ex. 1010, 2). Patent Owner does not contest this construction, but argues that “no express construction of this term is necessary and that it may be given its plain and ordinary meaning.” Prelim. Resp. 29 (citing Ex. 2004 ¶ 54).

In the related IPR, we determined that no express construction was necessary. *Google*, slip op. at 15. Likewise, we need not construe the term here, because neither party in this case argues that the meaning would affect the outcome of our Decision. *See Nidec Motor Corp. v. Zhongshan Broad Ocean Motor Co.*, 868 F.3d 1013, 1017 (Fed. Cir. 2017) (“[W]e need only construe terms ‘that are in controversy, and only to the extent necessary to resolve the controversy.’” (quoting *Vivid Techs., Inc. v. Am. Sci. & Eng’g, Inc.*, 200 F.3d 795, 803 (Fed. Cir. 1999))).

3. “*3D pointing device*”

The preamble of claim 1 recites a “three-dimensional (3D) pointing device,” and the term “3D pointing device” appears throughout the claim and in the preamble of claims 3–5. Ex. 1001, 18:54, 58, 65, 19:1–2, 17, 33, 34, 42. Petitioner is silent as to any express construction of this term. *See* Pet. 12–16.

When we instituted trial in the related IPR, we preliminarily adopted Patent Owner’s proposed construction in that proceeding, namely “a device capable of sensing movement and orientation in three dimensions to point to or control actions on a display.” *Google*, slip op. at 15–16 (citations omitted). In this proceeding, Patent Owner has shifted position in light of constructions in parallel district court litigations. *See* Prelim. Resp. 27–29; *see also* Exs. 2003, 7–8; 2004 ¶ 33, 52–53; 2006, 2; 2007, 6–7. Patent Owner now asks us to construe the term as in the district court cases: “a handheld device that detects the motion of said device in three-dimensions and is capable of translating the detected motions to control an output on a display.” Prelim. Resp. 26.

The evidence that Patent Owner presents in this proceeding may justify reaching a different construction under the civil-action standard than under the broadest reasonable interpretation. However, as we discuss below, the prior art discloses handheld devices, and thus we would reach the same ultimate conclusion in this Decision regardless of whether we construe *3D pointing device* according to its broadest reasonable interpretation as in the related IPR, or under the narrower construction adopted in the district court cases. Because we need not construe claim terms unless they are material to resolving the disputed issues, we do not expressly construe *3D pointing device* for the purpose of this Decision. *See Nidec*, 868 F.3d at 1017.

C. ASSERTED UNPATENTABILITY OF CLAIMS 1 AND 3–5 AS OBVIOUS OVER ZHANG IN VIEW OF BACHMANN

Petitioner’s sole ground for seeking *inter partes* review of the ’438 patent is that claims 1 and 3–5 would have been obvious over Zhang in view of Bachmann. Pet. 3. A claim is unpatentable for obviousness under 35

U.S.C. § 103 if the differences between the claimed subject matter and the prior art are “such that the subject matter as a whole would have been obvious at the time the invention was made to a person having ordinary skill in the art to which said subject matter pertains.” *KSR Int’l Co. v. Teleflex Inc.*, 550 U.S. 398, 406 (2007). We resolve this question on the basis of underlying factual determinations, including (1) the scope and content of the prior art, (2) any differences between the claimed subject matter and the prior art, (3) the level of skill in the art, and (4) any objective indicia of obvious or non-obviousness (i.e., secondary considerations) that may be in evidence.⁷ *See Graham v. John Deere Co.*, 383 U.S. 1, 17–18 (1966).

We discussed the level of ordinary skill in the art in part III.A above. Here, we discuss the remaining *Graham* factors as they relate to Petitioner’s allegation that claims 1 and 3–5 would have been obvious over Zhang in view of Bachmann.

1. *Overview of Zhang*

Zhang describes a “universal pointing device to control home entertainment systems and computer systems using spatial orientation sensor technologies.” Ex. 1005 ¶ 7. This device includes “a set of orientation sensors that detect the device’s current orientation.” *Id.* ¶ 8. These orientation sensors include “a two-axis magnetic sensor [that] identifies the device’s azimuth angle by detecting the earth’s magnetic field, and a dual-

⁷ At this stage, the parties have not produced evidence to support objective indicia of obviousness or non-obviousness, except to the extent this may include Patent Owner’s argument that Zhang and Bachmann teach away from attaching additional sensors to Zhang’s circuit board. *See* Prelim. Resp. 38–41. We address Patent Owner’s teaching-away arguments below.

axis accelerometer sensor [that] identifies the device's inclination angle by detecting the earth's gravity." *Id.* Microprocessor or logic circuits translate signals from these orientation sensors into pointing direction information. *Id.* When a user points the device to an arbitrary position on a 2D display, the orientation sensors inside the device detect the orientation and generate a pointing direction signal. *Id.* ¶ 21. Via encoding and transmission of the signal to a display control unit, and subsequent decoding and processing of the transmitted signal, the system superimposes a pointer image onto a video input signal displayed on a screen. *Id.* "The user perceives that the pointer is moved following the aiming line of sight." *Id.*

Zhang's Figure 3 is reproduced below:

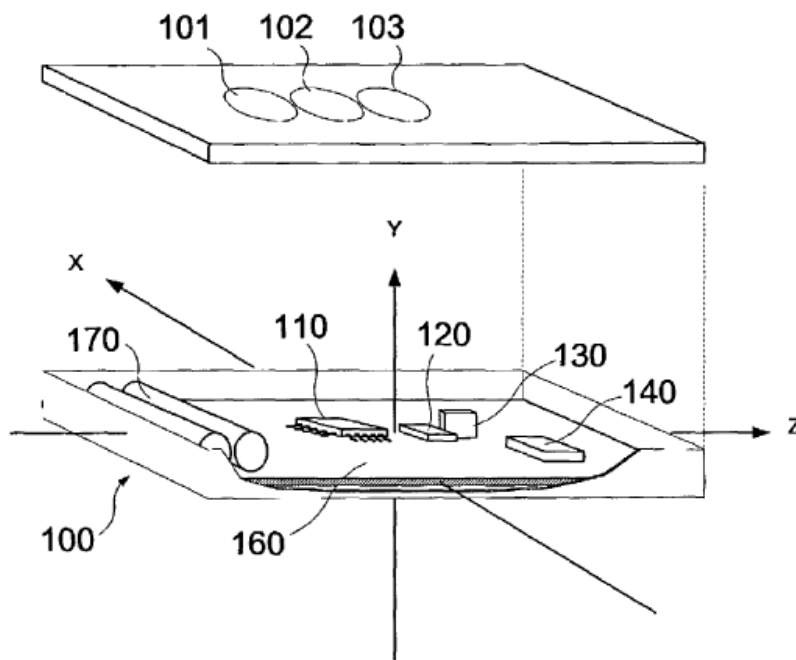

FIG. 3

Figure 3 depicts device 100, which includes sets of orientation sensors 120 (detecting yaw, or azimuth angle) and 130 (detecting pitch, or inclination

angle) mounted on printed circuit board (PCB) 160 to detect device 100's orientation changes. *Id.* ¶ 25. Further, “microcontroller 110 provides computation power for calculating and encoding the orientation signal output from the orientation sensor.” *Id.* Zhang states that other than sensors 120 and 130, “[a]dditional sensors (not shown in the picture) could be used to detect [the] device's roll angle which may provide an additional dimension of control.” *Id.* Although Zhang expressly illustrates orientation detection with magnetic field and acceleration sensors, it teaches that “the orientation detection may not be limited to these types of sensors,” and that other sensors such as a “gyro sensor” can be used. *Id.* ¶ 26.

2. *Overview of Bachmann*

Bachmann describes “a method and apparatus for tracking the posture of a body.” Ex. 1004, 4:59–60. In one embodiment, Bachmann describes “a system having a plurality of sensors, each mounted to a limb of an articulated rigid body [that] can be used to track the orientation of each limb.” *Id.* at 5:25–28. Thus, “body posture can be tracked and introduced into a synthetic environment, thereby allowing a user to interface with the synthetic environment.” *Id.* at 5:28–31. In one embodiment, “the sensors include a three-axis magnetometer and a three-axis accelerometer.” *Id.* at 7:34–35. In another embodiment, “the magnetometers and accelerometers are supplemented with angular rate detectors configured to detect the angular velocity of the sensor.” *Id.* at 7:35–40.

Bachmann uses a filter, in conjunction with data supplied by the sensors, “to produce a sensor orientation estimate expressed in quaternion form.” *Id.* at 7:32–34. Figure 3 of Bachmann is a block diagram of this filter:

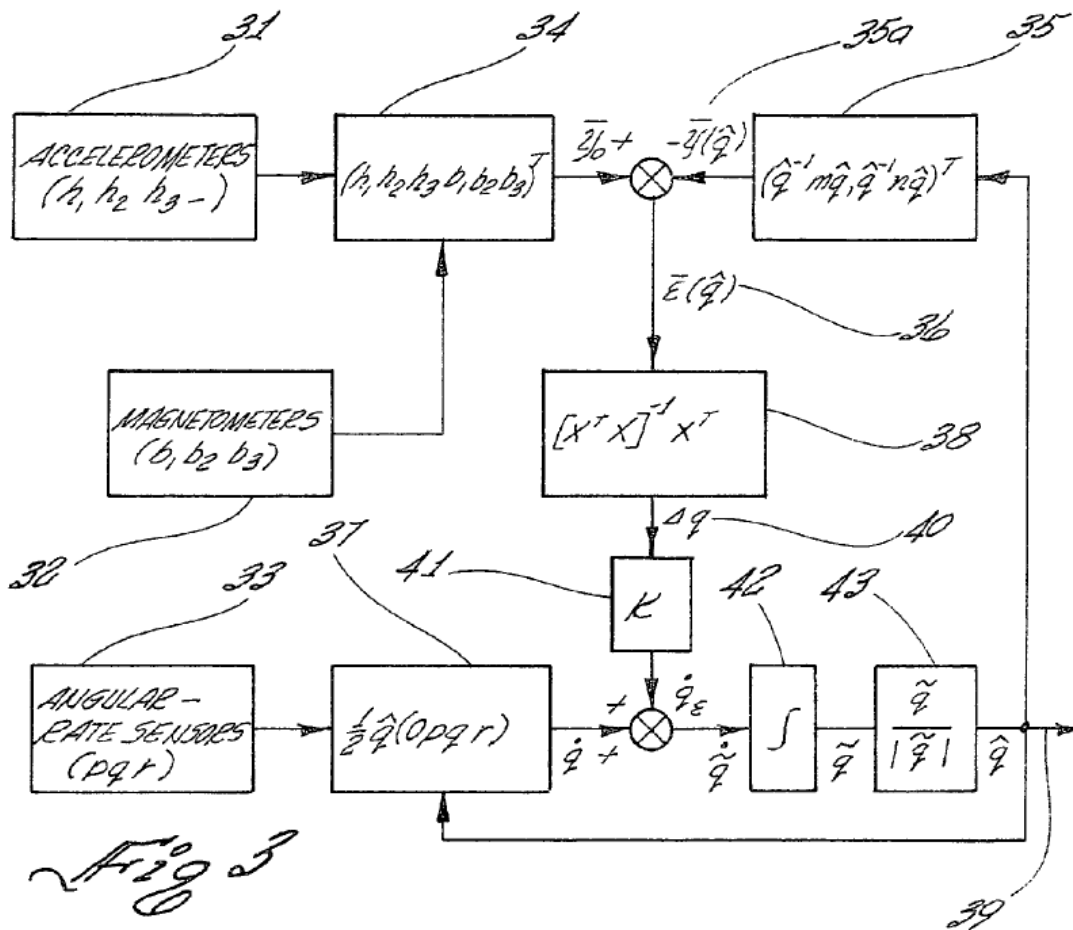

Id. at 4:46–48. As depicted in Figure 3, the filter takes measurement inputs from angular rate sensors 33, which measure sensor orientation to produce angular rate information 37, and these measurements contain noise. *Id.* at 10:17–20. According to Bachmann, “output 33 of angular rate detectors tends to drift over time . . . unless this orientation is continuously corrected using ‘complementary’ data from additional sensors (here, accelerometer 31 and magnetometer 32).” *Id.* at 10:36–42. Thus, the filter converts angular rate data 37 to a rate quaternion \dot{q} and corrects \dot{q} by adding a correction factor \dot{q}_ε derived from accelerometers 31 and magnetometers 32. *See id.*; *see also* Ex. 1002 ¶ 67 (testimony of Prof. Sarrafzadeh). The corrected rate quaternion \tilde{q} is then integrated (42) and normalized (43) to produce output \hat{q}

(39), which “describes [a] new value for estimated orientation of the sensor.” *Id.* at 10:33–36.

To obtain correction factor q_ε , the filter combines accelerometer 31 and magnetometer 32 measurements into a single vector \vec{y}_0 (34). *See id.* at 8:37–51. The filter then compares measurement vector \vec{y}_0 with calculated vector $\vec{y}(\hat{q})$ (35a), which is a predicted value derived from applying a physical model to the updated orientation estimate \hat{q} . *See id.* at 8:52–9:8, 9:65–10:2. Measurement error $\vec{\varepsilon}(\hat{q})$ (36) is the difference between measurement vector \vec{y}_0 and calculated vector $\vec{y}(\hat{q})$. *Id.* at 9:13, 10:2–5. The filter uses error $\vec{\varepsilon}(\hat{q})$ in equations to obtain the correction factor q_ε and update the next orientation estimate \hat{q} . *See id.* at 10:46–11:26, Fig. 3.

3. *Petitioner’s Rationale for Obviousness*

Petitioner contends that a person of ordinary skill in the art would have combined Zhang’s 3D pointing device with Bachmann’s additional rotational sensors and method for compensating rotations. Pet. 17. In support, Petitioner provides a rationale for this combination, *id.* at 17–36, and a detailed claim mapping for claims 1 and 3–5, *id.* at 36–66.

Pointing to Zhang’s statement that orientation detection may not be limited to magnetic-field and accelerometer sensors, and that “a gyro sensor[] can also be used in the pointing control system,” *id.* at 21 (emphasis omitted) (quoting Ex. 1005 ¶ 26), Petitioner reasons that it would have been obvious to add Bachmann’s angular-rate sensors, *id.* at 27–30. Petitioner cites testimony by Prof. Sarrafzadeh that one of ordinary skill in the art would have understood such additional sensors to provide at least two benefits: (1) allowing the device to detect different modes of movement,

such as a roll angle; and (2) increasing the overdetermination (the amount of information beyond that necessary to determine orientation) to enable better error and noise control. *Id.* at 28 (citing Ex. 1002 ¶ 76).

In articulating a motivation to combine the references, Petitioner also points to Bachmann’s disclosure that nine-axis sensors were known in the art and commercially available. *Id.* at 28–29 (citing Ex. 1004, 14:37–57).

Petitioner particularly points to Bachmann’s disclosure of using its sensors to track motion in “**hand-held devices**, swords, pistols, or simulated weapons.” *Id.* at 29–30 (quoting Ex. 1004, 13:42–48). As Petitioner summarizes, “Zhang’s device has a housing, sensors and . . . software for using sensor output to calculate the orientation of the device,” and “Bachmann has the same, but uses additional sensors and a modified calculation.” Pet. 31 (citing Ex. 1002, ¶ 82). Petitioner reasons that “[t]hese functional blocks (sensors and calculations) could have been substituted for the same functional blocks in Zhang requiring only ordinary skill to implement,” and that “[t]here would have been no unexpected results—only the *expected* improvement promised by Bachmann.” *Id.* at 32 (citing Ex. 1002 ¶ 82).

Petitioner also argues that Bachmann teaches a “comparison to compare the first signal set with the second signal set” as recited in claim 1. *Id.* at 53 (emphasis omitted). In Bachmann’s filter, according to Petitioner, “[t]he claimed **comparison** happens in forming the correction factor \hat{q}_ε , . . . in steps 34–41 of Fig. 3.” *Id.* at 54. In particular, Petitioner argues that the recited comparison happens when the filter compares actual measurement vector \vec{y}_0 with calculated measurement vector $\vec{y}(\hat{q})$ (35a), which is derived from updated orientation estimate \hat{q} . *Id.* at 56. According to Petitioner, this is

a “comparison,” as recited in the claim, because “the calculation of the correction factor q_ε uses signals from six sensor axes, the accelerometers (*i.e.* the second signal set) and angular rate sensors (*i.e.* the first signal set), and reduces errors associated with the sensors.” *Id.* at 57. In other words, Petitioner argues that vector \vec{y}_0 is derived from the actual accelerometer measurements (the first signal set), and vector $\vec{y}(\hat{q})$ is derived, through a transformation of \hat{q} , from the angular velocity measurements (the second signal set), and that the filter compares \vec{y}_0 with $\vec{y}(\hat{q})$. *See id.* at 59–60.

4. *Patent Owner’s Responses to the Petition*

Below, we discuss Patent Owner’s preliminary responses to Petitioner’s obviousness rationale and comparison of the claims with the prior art.

a. Whether Bachmann Is Analogous Art

Patent Owner contends that Bachmann is not analogous art. Prelim. Resp. 30–34. Patent Owner similarly presented this argument in the related IPR, and we did not find this persuasive based on the preliminary record of that case, *Google*, slip op. at 26–28. Patent Owner now contends that limiting the construction of *3D pointing device* to a handheld device compels a different conclusion. *See* Prelim. Resp. 32–33. On the preliminary record, we do not agree.

As Patent Owner acknowledges, *see id.* at 33, two separate tests define the scope of analogous prior art: (1) whether the art is from the same field of endeavor, regardless of the problem addressed; and (2) if the reference is not within the field of the inventor’s endeavor, whether the reference is still “reasonably pertinent to the particular problem with which

the inventor is involved.” *In re Bigio*, 381 F.3d 1320, 1325 (Fed. Cir. 2004). Patent Owner contends that Bachmann does not satisfy either test.

Regarding the first test, Patent Owner argues that “[t]he field of endeavor of the ’438 Patent is handheld ‘3D Pointing Devices,’ or, alternatively and more broadly, ‘pointing devices and their applications.’” Prelim. Resp. 32 (citing Ex. 2004 ¶ 77). Patent Owner argues that this differs from Bachmann’s field of endeavor, which Patent Owner contends is “motion tracking of articulated bodies.” *Id.* at 30.

Based on the present record, this characterizes the relevant field too narrowly. Patent Owner looks to the term “three-dimensional (3D) pointing device” in the claim preamble. *See id.* at 31. While claim language may define a specific invention, the invention’s field of endeavor is broader, and informed by “explanations of the invention’s subject matter in the patent application, including the embodiments, function, and structure of the claimed invention.” *Bigio*, 381 F.3d at 1325 (citing *In re Wood*, 599 F.2d 1032, 1036 (CCPA 1979)). Moreover, “[t]he field of endeavor of a patent is not limited to the specific point of novelty, the narrowest possible conception of the field, or the particular focus within a given field.” *Unwired Planet, LLC v. Google Inc.*, 841 F.3d 995, 1001 (Fed. Cir. 2016). Bachmann describes its own field as “methods and apparatus for tracking the orientation . . . of an object.” Ex. 1004, 1:18–20, 13:47–48. On the present record, this characterization would equally characterize the field that the ’438 patent reflects, which concerns methods for tracking the orientation of objects containing sensors.

Patent Owner also argues that Bachmann fails the second test because Bachmann “in no way addresses the problem of translating the detected

motions of a handheld 3D pointing device to a movement pattern to control actions on a display.” Prelim. Resp. 32. However, based on the record before us, this too narrowly defines the problem with which the inventor is involved. The ’438 patent is more generally involved with the problem of “compensating accumulated errors of signals of [a] six-axis motion sensor module in dynamic environments associated in a spatial pointer reference frame.” Ex. 1001, 5:51–54. Bachmann provides one solution to that problem. Also, although Bachmann gives examples of tracking the posture of articulated rigid bodies, Bachmann’s teachings are also more generally “relate[d] to methods and apparatus for tracking the orientation . . . of an object,” and these objects may include “hand-held devices.” Ex. 1004, 1:18–20, 13:47–48.

In light of these teachings, Bachmann “logically would have commended itself to [the] inventor’s attention in considering [the] problem” of compensating accumulated measurement errors in a six-axis motion sensor. *See In re Clay*, 966 F.2d 656, 659 (Fed. Cir. 1992). Thus, we find on the present record that Bachmann is both within the same field of endeavor as the ’438 patent, and reasonably pertinent to the problem addressed.

Patent Owner notes that the Patent Office has cited Bachmann “as a reference in twenty publications during various examination proceedings,” of which “not a single one of them relates to a pointing device, let alone a 3D pointing device.” *See* Prelim. Resp. 33–34. Patent Owner contends that this fact “corroborates Dr. LaViola’s opinion that a [person of ordinary skill in the art] would not have considered *Bachmann* to have logically commended itself to the problems of using a handheld 3D pointing device to control actions on a display and compensating for accumulated sensor errors

of such a device.” *Id.* at 34 (citing Ex. 2004 ¶ 80). However, this does not meaningfully mitigate our finding, because Dr. LaViola’s opinion rests on the same overly narrow characterization of the problem that the ’438 patent addresses, which we do not find persuasive on this record.

b. Whether the Art Teaches a “3D Pointing Device”

Patent Owner argues that Petitioner is incorrect that Zhang discloses a “three-dimensional (3D) pointing device.” Prelim. Resp. 36. According to Patent Owner, Zhang only discloses “a four-axis sensor module,” and thus “it cannot detect the roll of the pointing device.” *Id.* at 37 (citing Ex. 2004 ¶ 85). Thus, according to Patent Owner, it is only a “2D pointing device.” *Id.* at 38. While Patent Owner acknowledges that Zhang discloses “that adding additional sensors could provide the ability to detect the device’s roll,” Patent Owner argues that Zhang “does not disclose how to do so,” and also teaches that “each new sensor added to the device brings with it additional noise and errors that must be accounted for in calculating the orientation of the device, which is not a simple task.” *Id.* at 20 (citing Ex. 1005 ¶ 25); *see also id.* at 38 (citing Ex. 1005 ¶ 4). Moreover, Patent Owner argues that Zhang “explicitly teaches away from simply using the additional accelerometers of *Bachmann* to detect further dimensions of movement.” *Id.* at 38–39 (citing Ex. 2004 ¶ 88).

Having considered these arguments, we determine that Petitioner’s arguments in favor of combining Zhang with *Bachmann* are sufficiently persuasive on the present record. Although Zhang focuses on embodiments in which orientation sensors 120 and 130 measure yaw and pitch angles of a handheld device, *see* Ex. 1005, Fig. 3, Zhang also teaches that additional sensors “could be used to detect [the] device’s roll angle which may provide

an additional dimension of control.” Ex. 1005 ¶ 25. This teaching is consistent with “a 3D pointing device” under either the broadest reasonable interpretation or the civil action standard.

Also, Patent Owner’s teaching-away argument is unpersuasive on the present record. Zhang teaches that there are concerns with using “piezoelectric sensors [to] detect only the dynamic changes of acceleration,” because “acceleration measurement errors are introduced,” and “[t]he accumulated acceleration error in the integration process would eventually render the device unusable.” Ex. 1005 ¶ 4. However, Patent Owner does not adequately explain why this specific disadvantage of integrating such acceleration-based sensors teaches away from the invention, in light of the teachings in Zhang and Bachmann that one may use other types of sensors. *See In re Fulton*, 391 F.3d 1195, 1201 (Fed. Cir. 2004) (a prior art reference does not teach away from the claimed subject matter unless the prior-art reference also criticizes, discredits, or otherwise discourages the solution claimed). Zhang’s teaching is broad as to the type of sensors that one may use in the invention. *See* Ex. 1005 ¶ 26 (“[T]he orientation detection may not be limited to [a magnetic field sensor or accelerometer]. Other sensors, for example, a gyro sensor, can also be used in the pointing control system.”); *see also id.* ¶ 4 (noting that some commercial magnetic sensors “are packaged to detect two-axis, *even three-axis*, magnetic field changes and provide a linear output to the direction of the magnetic field flux.” (emphasis added)).

Patent Owner also argues that Bachmann, individually, fails to disclose a 3D pointing device, because “the signals measured by the sensors in *Bachmann* are not mapped onto a display screen as a movement pattern

for the purpose of pointing to or controlling actions on the display screen.” Prelim. Resp. 39. This argument is not persuasive, because it attacks Bachmann as a reference individually, without considering it in combination with Zhang. *See In re Keller*, 642 F.2d 413, 425 (CCPA 1981) (“The test for obviousness is not . . . that the claimed invention must be expressly suggested in any one or all of the references.”)

c. Whether the Art Teaches “a Six-Axis Motion Sensor Module Attached to the PCB”

Patent Owner argues that Petitioner is incorrect that Zhang discloses “a six-axis sensor module attached to the PCB.” Patent Owner acknowledges that Zhang “discloses that its sensors are attached to the circuit board.” Prelim. Resp. 40 (citing Ex. 1005 ¶ 25). However, according to Patent Owner, Zhang “only discloses a four-axis sensor module.” *Id.* (citing Ex. 2004 ¶ 92).

On the present record, we determine that Petitioner has sufficiently shown that a person of ordinary skill in the art would have had reason to mount Bachmann’s additional sensors on Zhang’s PCB, because Zhang teaches mounting all its sensors “orthogonally” to each other, and a skilled artisan would have understood this means mounting them on the PCB. *See* Pet. 41–42 (citing Ex. 1005 ¶ 25; Ex. 1002 ¶ 107).

Patent Owner also argues that Bachmann “teaches away from attaching all of its sensors on the PCB,” because Bachmann “specifically states that the individual components of the disclosed MARG (Magnetic, Angular Rate, Gravity) sensor should ‘be integrated using a single integrated circuit board *with the accelerometers mounted separately.*’” Prelim. Resp. 41 (citing Ex. 1004, 14:49–51).

The quote in Bachmann, however, only states that in the MARG embodiment, “[t]he individual components *can be* integrated using a single integrated circuit board with the accelerometers mounted separately.” Ex. 1004, 14:49–51 (emphasis added). This permissive statement of a possible embodiment does not, based on the present record, appear to “criticize, discredit, or otherwise discourage the solution claimed” in the ’438 patent. *Fulton*, 391 F.3d at 1201.

Patent Owner further argues that “[m]ounting these additional sensors to Zhang’s PCB is not as clear-cut as Petitioner’s expert would have the Board believe and would require a level of skill greater than that possessed by a [person having ordinary skill in the art] at the time of invention.” Prelim. Resp. 41 (citing Ex. 2004 ¶ 95). In the preliminary proceedings of an *inter partes* review, any genuine issue of material fact created by differing testimonial evidence is “viewed in the light most favorable to the petitioner.” See 37 C.F.R. § 42.108. Therefore, for the purpose of this decision, we resolve this issue in favor of Petitioner’s declarant. See, e.g., Ex. 1002 ¶¶ 87 (“[A] person of ordinary skill would have been able to integrate these sensors into Zhang’s 3D pointing device using standard amplifiers, filters, samplers, and analog-to-digital converters, adjusting as necessary.”), 75 (“Including Bachmann’s nine-axis sensor into Zhang’s 3D pointer is therefore nothing more than following Zhang’s suggestions.”).

d. Whether the Art Teaches the Recited
“Comparison”

Patent Owner argues that Bachmann’s method “operates very differently from that of the ’438 Patent.” Prelim. Resp. 42. According to Patent Owner, this includes “several key differences” such as that

“*Bachmann* does not make use of elements of an extended Kalman filter,” that it “requires two integrations” whereas the ’438 patent “only requires a single integration,” that it “makes use of Gauss-Newton iteration in order to compute the error term,” and that *Bachmann* “never uses the terms [*prediction* or *predicted*] in the claims or specification.” *Id.* at 42–43 (citing Ex. 2004 ¶ 63; Ex. 1002 ¶¶ 69–70).

These arguments are not persuasive on the present record, because the challenged claims are open-ended “comprising” claims. *See* Ex. 1001, 18:54–19:26, 19:33–48. Thus, they allow for the presence of additional steps and features not specifically recited in the claims. *See Solvay S.A. v. Honeywell Int’l Inc.*, 742 F.3d 998, 1005 (Fed. Cir. 2014). Also, Patent Owner does not clearly explain how it contends Petitioner is incorrect that *Bachmann* obtains a “predicted measurement,” even if *Bachmann* uses different terminology. *See* Pet. 59–61; Ex. 1002 ¶¶ 69–70.

e. Whether Zhang in View of *Bachmann* Teaches the Additional Limitations of Dependent Claims 3–5

Claim 3 depends from claim 1 and further recites “wherein the PCB enclosed by the housing comprises at least one substrate having a first longitudinal side configured to be substantially parallel to a longitudinal surface of the housing.” Ex. 1001, 19:32–35. Patent Owner makes no distinct arguments with respect to claim 3. *See* Prelim. Resp. 43.

Claim 4 depends from claim 1 and further recites “wherein said resultant angles of the resulting deviation include yaw, pitch and roll angles about each of three orthogonal coordinate axes of the spatial pointer reference frame.” Ex. 1001, 19:36–41. Patent Owner argues that Zhang “cannot detect roll, and while it suggests that adding extra sensors could help

the device detect roll, it does not suggest how one of skill in the art might go about doing so.” Prelim. Resp. 44. Therefore, according to Patent Owner, the addition of a roll sensor would not have led to a predictable result or been an obvious improvement in the art. *See id.*

Patent Owner’s argument is unpersuasive on this record. As discussed above in part III.C.4.c, Petitioner has sufficiently shown that a person of ordinary skill in the art would have had reason to mount all of Bachmann’s sensors, including a roll sensor, on Zhang’s PCB.

Claim 5 depends from claim 1 and further recites “wherein the data transmitting unit of the processing and transmitting module is attached to the PCB enclosed by the housing and transmits said first and second signal of the six-axis motion sensor module to the computing processor via electronic connections on the PCB.” Ex. 1001, 19:43–48.

Petitioner identifies the “data transmitting unit” in Zhang with the “command delivery unit” set of circuitry between sensors 120 and 130 and processor 110, depicted in a block diagram in Zhang’s Figure 5. Pet. 46–47. Petitioner argues that in Zhang, “the data transmitting unit is *functionally* between sensors (*e.g.* 120 and 130) and the processor (*e.g.* 110), and must be electrically connected to the sensors and the processor.” Pet. 66 (citing Ex. 1002 ¶¶ 150–53). Thus, Petitioner argues that “it would have been obvious to also attach the **data transmitting unit** to the same PCB, and to use the PCB traces (electronic connections on the PCB) in a known fashion to form the required connections.” *Id.* According to Petitioner, “[t]his would have been considered superior to adding a second PCB, for which the person of skill would have needed to find additional space and create longer board-to-board connections.” *Id.*

Patent Owner identifies the recited “data transmitting unit” with Zhang’s “command delivery unit” which can be external to the pointing device, and therefore not attached to the PCB. Prelim. Resp. 45 (citing Ex. 1005 ¶ 8).⁸ However, Zhang discloses that the purpose of the command delivery unit is to forward commands from the handheld pointing device “to any remote controllable target device using an infrared beam to execute the desired operation.” Ex. 1005 ¶ 8. Patent Owner does not explain how it corresponds to the data transmitting unit in claim 1, which has the function of “transmitting said first and second signal sets” to the “computing processor” on the pointing device (which Petitioner identifies as processor 110). Ex. 1001, 19:4–9.

Patent Owner’s argument is unpersuasive on the present record, and we determine that Petitioner has sufficiently shown that a skilled artisan would have had reason to attach Zhang’s data transmitting unit to the PCB, as recited in claim 5.

5. *Conclusion on Whether the Petition Warrants Inter Partes Review*

After considering the evidence and arguments presented in the Petition and Preliminary Response, we determine that Petitioner has demonstrated a reasonable likelihood of success in proving that claims 1 and 3–5 of the ’438 patent are unpatentable. Therefore, we determine that the Petition warrants the institution of an *inter partes* review.

⁸ Patent Owner acknowledges that in addition to being external, the command delivery unit may also be “integrated into the pointing device.” Prelim Resp. 45 (citing Ex. 2004 ¶ 104; Ex. 1005 ¶ 8); *see also* 1005 ¶ 23 (“The command deliver[y] unit . . . can be embedded inside the pointing device 100.”).

D. JOINDER

Because we conclude that the Petition warrants the institution of an *inter partes review*, we have discretion to join Petitioner as a party to the related IPR. *See* 35 U.S.C. § 315(c).

A joinder motion should (1) set forth reasons why joinder is appropriate; (2) identify any new grounds of unpatentability asserted in the petition; (3) explain what impact, if any, joinder would have on the trial schedule for the existing review; and (4) address specifically how briefing and discovery may be simplified. *Kyocera Corp. v. Softview LLC*, Case IPR2013-00004, slip op. at 4 (PTAB Apr. 24, 2013) (Paper 15). Petitioner’s Motion addresses each of these considerations. Mot. 4–8.

With respect to these factors, Petitioner contends that “[b]ecause these proceedings are substantively identical, good cause exists for joining this proceeding with the Google IPR so that the Board, consistent with 37 C.F.R. § 42.1(b), can efficiently ‘secure the just, speedy, and inexpensive resolution’ of the Samsung and Google petitions in a single proceeding.” *Id.* at 4. In addition, Petitioner asserts that joinder will not negatively impact the trial schedule “because the Samsung Petition presents no new issues or grounds of unpatentability,” and “relies on the same expert and the same declaration, only a single deposition is needed for the proposed joined proceeding.” *Id.* at 5–6.

Further, Petitioner “agrees to take an ‘understudy’ role which will simplify briefing and discovery.” *Id.* at 6. Specifically, Petitioner concedes to several limitations on its participation in the joined proceeding: (1) to consolidate all filings with the current petitioner, unless a filing concerns issues solely involving Petitioner; (2) to be prohibited from raising any new

grounds or introducing any arguments or discovery not introduced by the current petitioner; (3) to be bound by any agreement between Patent Owner and the current petitioner concerning discovery and/or depositions; and (4) not to receive any direct, cross-examination, or redirect time beyond that permitted under either 37 C.F.R. § 42.53 or any agreement between Patent Owner and the current petitioner. *Id.* at 7.

Patent Owner raises concerns that the instant Motion is one of four motions that have been filed by different parties: “A flood of joinder petitions of this kind prejudices Patent Owner, as it must now face the combined resources and efforts of all of the petitioners.” *Opp.* 4. In particular, Patent Owner contends that it is “unfathomable” that the four parties who have filed joinder motions, all major technology companies who are parties to district court litigation and have an interest in the outcome of the related IPR, “will truly take an ‘understudy’ role.” *Id.* at 5. Instead, Patent Owner hypothesizes that the petitioner parties will engage in “coordinated efforts to overwhelm” it as a small patent owner. *Id.*

Although we are not unsympathetic to these concerns, they are not persuasive in the context of the significant constraints Petitioner agrees to accept for its joinder to the related IPR—constraints that we can manage and enforce. As Petitioner states, “CyWee cannot credibly complain of having to face multiple Petitioners when it is CyWee’s own litigation activity that has prompted multiple Petitioners to challenge its patent.” *Reply* 3 (citing *Samsung Electronics Am., Inc. v. Uniloc 2017 LLC*, Case IPR2017-01797, slip op. at 33 (PTAB Feb. 6, 2018) (Paper 8)).

Patent Owner also contends that “[b]ecause the claim construction standard applied to IPRs shifted between the time that the Google IPR was

filed and the time that Samsung's petition and Motion were filed, the Board will need to address the new issue of which claim construction standard would apply if Samsung were to join." Opp. 8. This contention is also unpersuasive. Because the petitioner in the related IPR filed its petition prior to the date the Board changed the claim construction standard it uses in trial proceedings, the related IPR will continue to use the broadest reasonable interpretation, regardless of the joinder of any parties to that proceeding. *See* 83 Fed. Reg. at 51,344 ("The Office will continue to apply the BRI standard for construing unexpired patent claims and proposed substitute claims in AIA proceedings where a petition was filed before the effective date of the final rule.").

Further, Patent Owner contends that joining Petitioner to the related IPR "raises new questions regarding [real parties in interest]." *Id.* at 10. But Patent Owner's bases, on the present record, for advancing this contention are speculative, grounded in its suspicion that "the petitioners seeking joinder to the Google IPR are working together." *Id.* According to Patent Owner, those petitioner parties "all utilize the Google Android operating system on their devices that are at issue at district court," and Patent Owner speculates "whether other undisclosed third parties are [real parties in interest] having a stake in the outcome of the Google IPR." *Id.* It is not apparent from these limited speculations that Patent Owner would be entitled to additional discovery regarding real parties in interest under the standards that apply for such discovery. Moreover, we have already denied Patent Owner's motion for additional discovery in the related IPR. *See Google LLC v. Cywee Group Ltd.*, Case IPR2018-01258 (PTAB June 20, 2019) (Paper 30).

In addition, Patent Owner argues that joining Petitioner to the related IPR “would be a waste of time, effort, and resources for the Board, the parties, and the district court.” Opp. 11. Patent Owner characterizes the district court action as being in a well-advanced state:

[T]he District Court Action has progressed substantially to the point that fact discovery has concluded, as has expert discovery as to the issues of validity and infringement. The deadline for case dispositive motions has recently passed and both CyWee and Samsung have moved for summary judgment and filed motions to strike expert opinions.

Id. But according to Petitioner, “that case has been stayed pending the Google IPR.” Reply 5 (citing *CyWee Grp. Ltd. v. Samsung Elecs. Co. Ltd.*, Case No. 2:17-cv-00140, D.I. 332 (E.D. Tex. Feb. 14, 2019)). We agree with Petitioner that this development renders Patent Owner’s argument moot.

In light of these considerations, we grant Petitioner’s motion and terminate this proceeding so that all further filings are made in the related proceeding to which Petitioner is joined.

IV. ORDER

It is

ORDERED that Petitioner’s Motion for Joinder is *granted* and Petitioner is joined as a party to IPR2018-01258;

FURTHER ORDERED that the grounds of unpatentability on which trial was instituted in IPR2018-01258 are unchanged and remain the only grounds on which trial has been instituted;

FURTHER ORDERED that the Scheduling Order and any modifications thereto entered in IPR2018-01258 will govern the schedule of the joined proceeding;

FURTHER ORDERED that the joined parties in IPR2018-01258 will file all papers jointly in the joined proceeding as consolidated filings, and will identify each such paper as “Consolidated,” except for papers that involve fewer than all of the parties;

FURTHER ORDERED that this proceeding is *terminated*;

FURTHER ORDERED that a copy of this Decision will be entered into the record of IPR2018-01258; and

FURTHER ORDERED that the case caption in IPR2018-01258 will be modified in accordance with the attached example to reflect joinder of Petitioner, as well as joinder of other petitions according to decisions issued concurrently with this one.

IPR2019-00535
Patent 8,441,438 B2

For PETITIONER:

Naveen Modi
Chetan Bansal
PAUL HASTINGS LLP
naveenmodi@paulhastings.com
chetanbansal@paulhastings.com

For PATENT OWNER:

Jay Kesan
DIMURO GINSBERG PC
jay@jaykesan.com

Example Case Caption for Joined Proceeding

UNITED STATES PATENT AND TRADEMARK OFFICE

BEFORE THE PATENT TRIAL AND APPEAL BOARD

GOOGLE LLC, ZTE (USA), INC.,
SAMSUNG ELECTRONICS CO., LTD.,
LG ELECTRONICS INC., HUAWEI DEVICE USA, INC.,
HUAWEI DEVICE CO. LTD., HUAWEI TECHNOLOGIES CO. LTD.,
HUAWEI DEVICE (DONGGUAN) CO. LTD.,
HUAWEI INVESTMENT & HOLDING CO. LTD.,
HUAWEI TECH. INVESTMENT CO. LTD., and
HUAWEI DEVICE (HONG KONG) CO. LTD.,

Petitioner,

v.

CYWEE GROUP LTD.,
Patent Owner.

Case IPR2018-01258
Patent 8,441,438 B2
